

SBML level3: rule-based, graph-based, domain-based

Michael Blinov

Theoretical Biology and Biophysics Group (T-10)

Los Alamos National Laboratory, USA

<http://cellsignaling.lanl.gov>

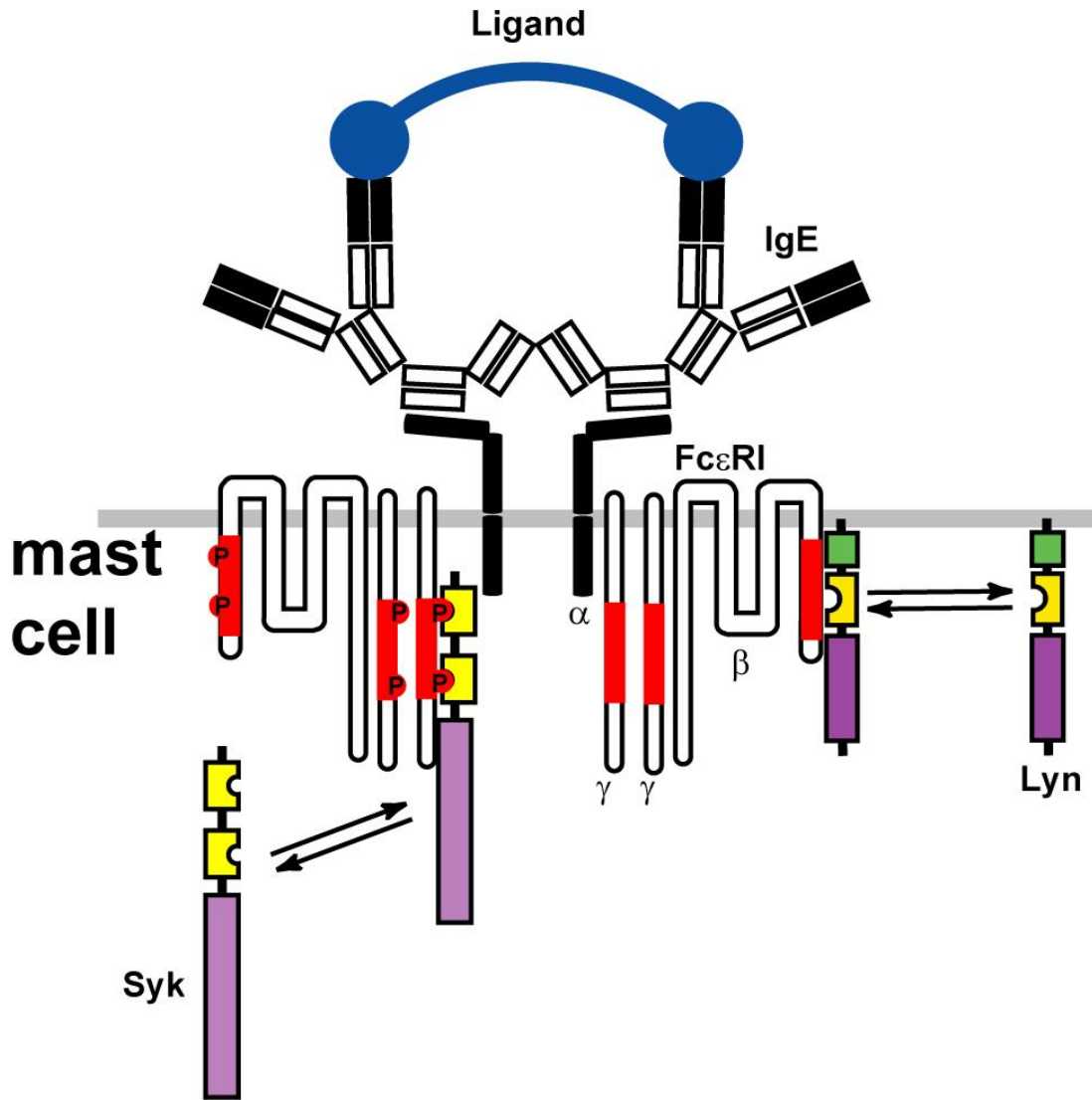

- Multi-state multi-component species
- Interactions specific to specific domains and sites of proteins
- Specifications of reactants and contents
- Species located in several compartments

SBML level 3 goal

- Chemical reactions model is a set of biophysical transformations among individual chemical species, as in SBML 2.
- SBML 3 has a goal to describe system in order to be able to generate a model.
- Not all simulation parameters must be defined in SBML level 3 to allow for model generation/simulation

Basic definitions

A species - a graph

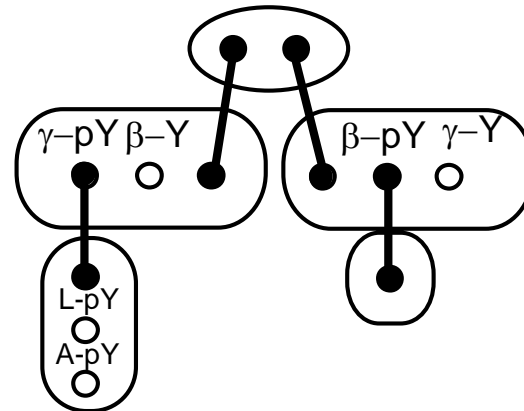

Nodes: Components, having attributes

Component: ITAM
 ComponentState: Y, pY



ComponentConnectivity: bound unbound unspecified
 ComponentCompartment: extracellular, intracellular

Partition: Molecules

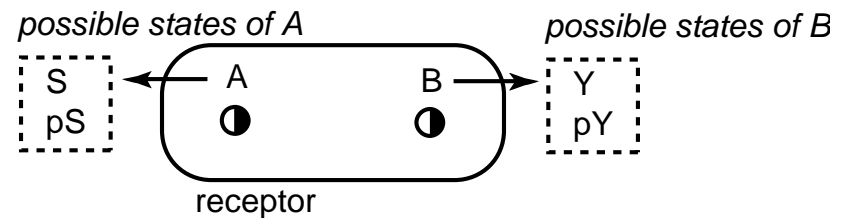

Species: fully defined (not necessary fully connected) graph

SykPS

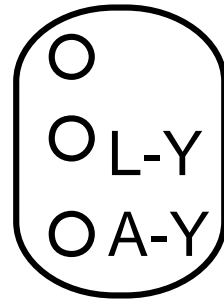

R-Lyn

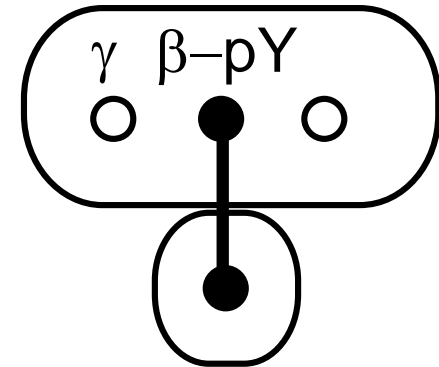

Attributes: states

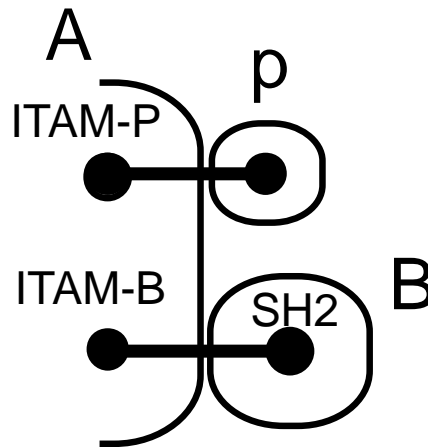
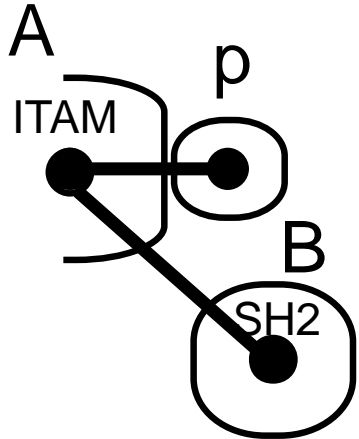
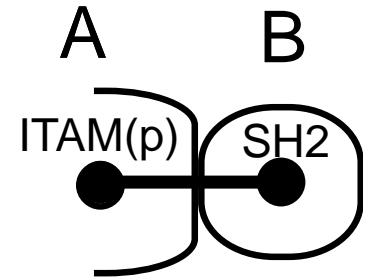
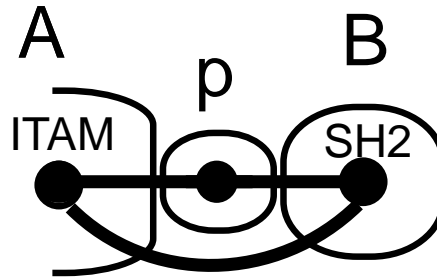
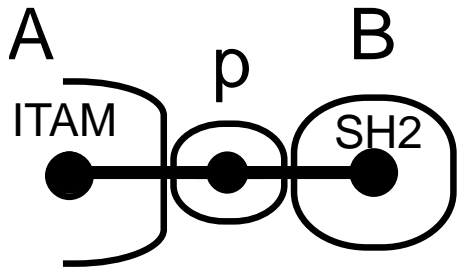

Attributes: states

Open dimer

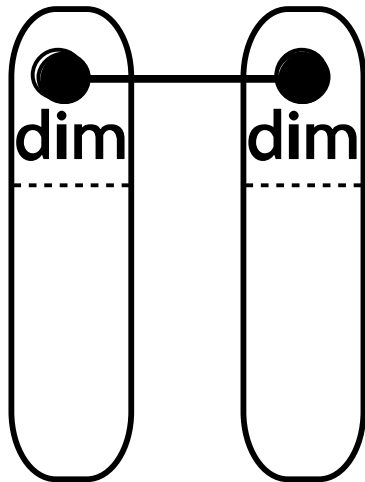

Open dimer
with ligand

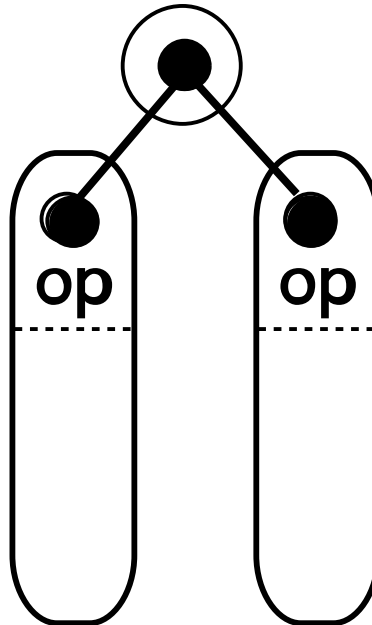

Closed dimer
with ligand

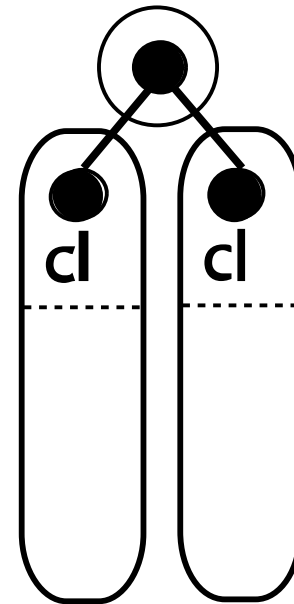

Attributes: connectivity + speciesGroups

SpeciesGroup

species in group



binding and internal states of A are unspecified

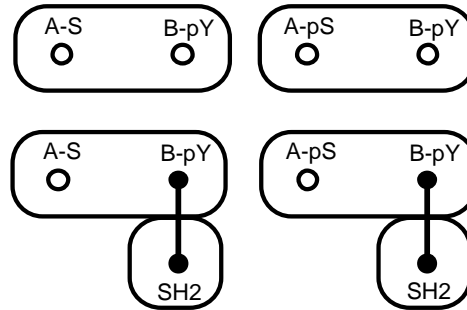

(a)

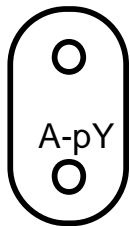

(b)

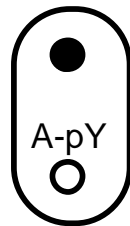

(c)

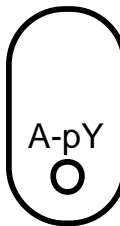

(d)

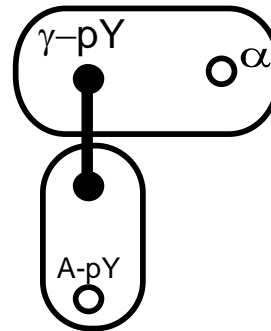

(e)

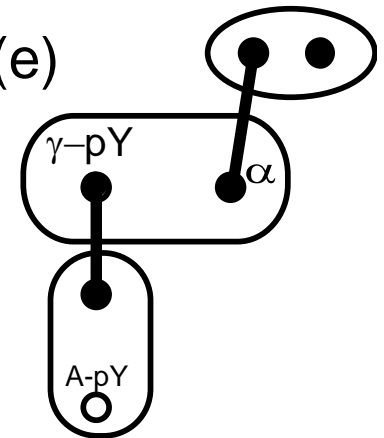

Reaction rules

Reaction rule

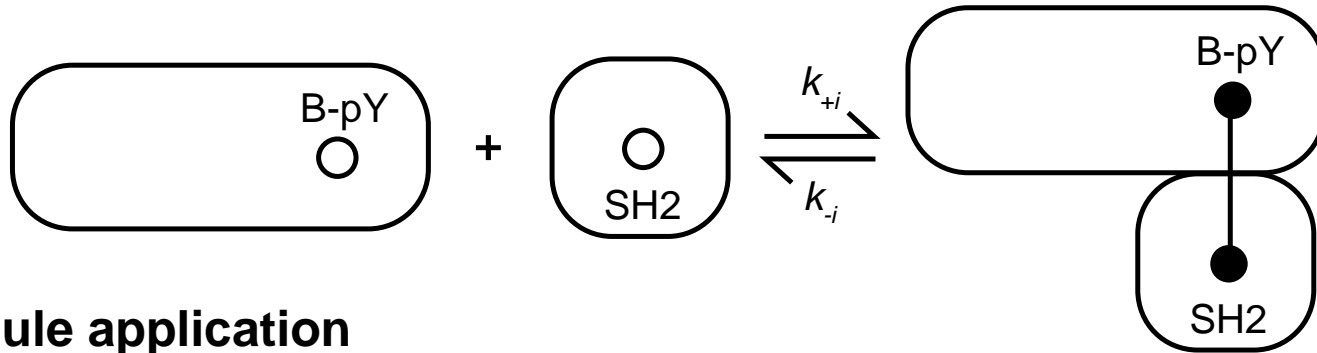

Rule application

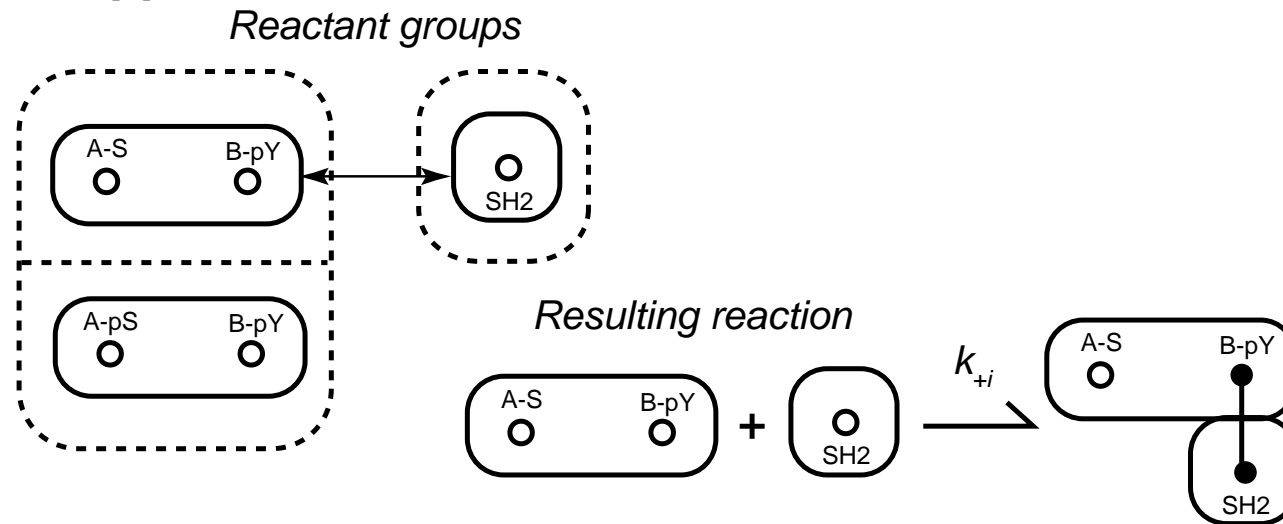

Reaction rules

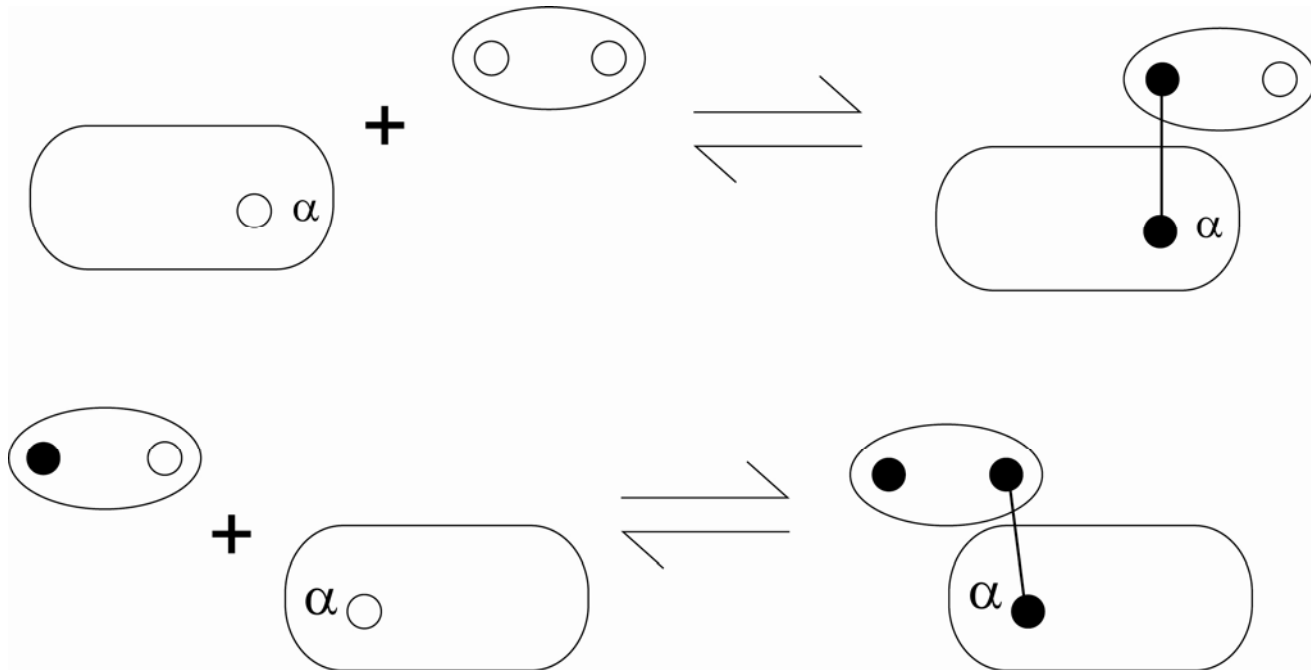

Reaction rules

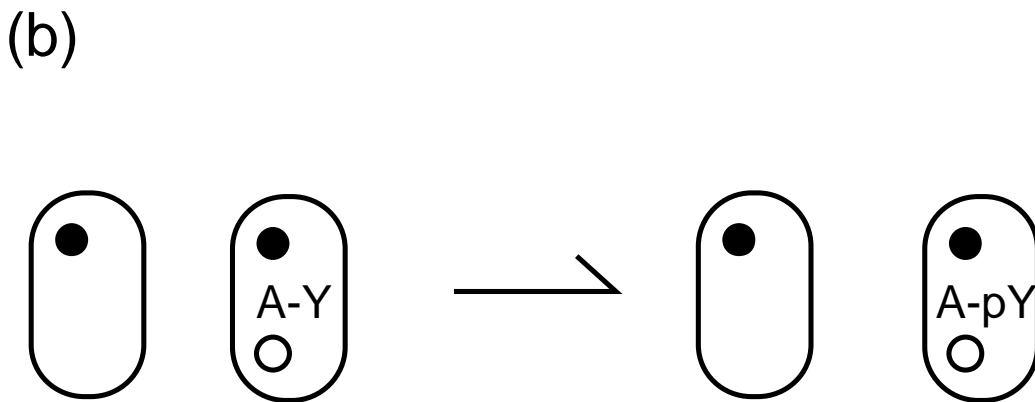
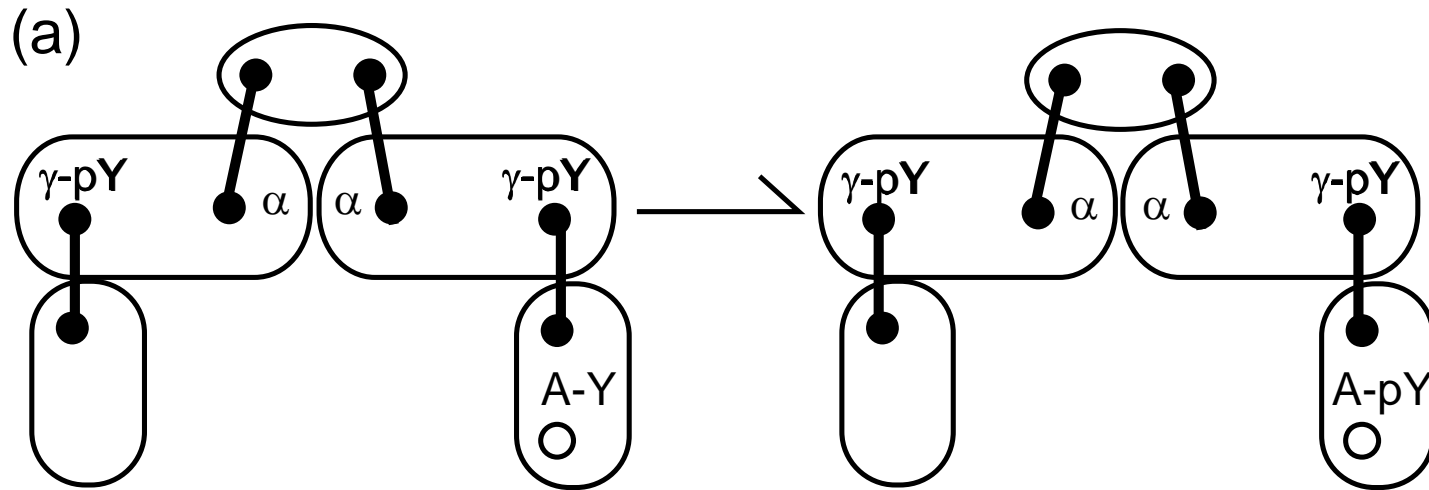

Reaction rules

Molecule definitions

Bivalent ligand



equivalent
binding sites



Bivalent receptor

Reaction rules

Ligand capture

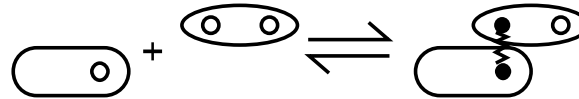

Receptor chain elongation



Closure of a ring with one receptor

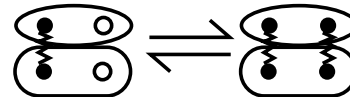

Closure of a ring with multiple receptors



second receptor must be
contained within the same
complex

Compartment attribute

Compartment="intra"

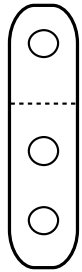

"intra"

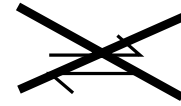
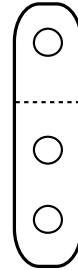

"extra"

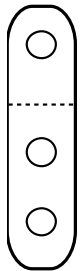
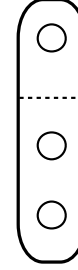

Compartment="extra"

Compartment="membrane"

Compartment="intra"

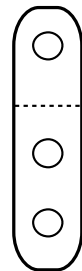

Compartment="intra"

"extra"

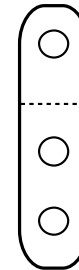

"membrane"

"intra"

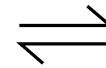

"intra"

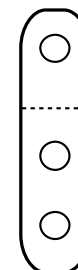

"intra"

"intra"

Observables=Macrospecies

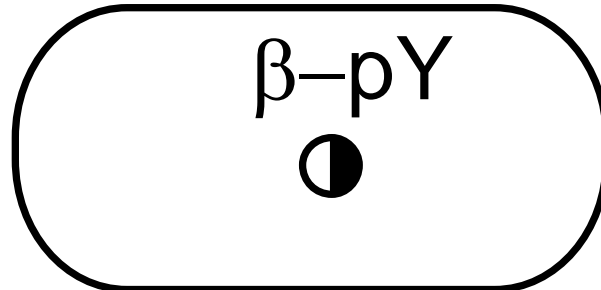
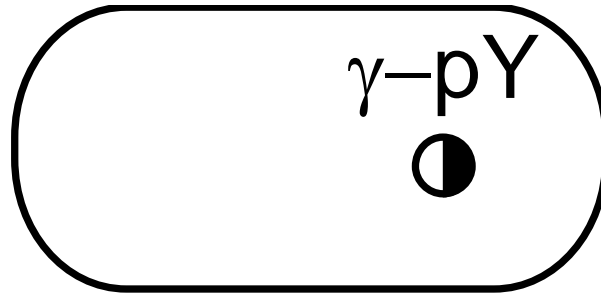

listOfMolecules

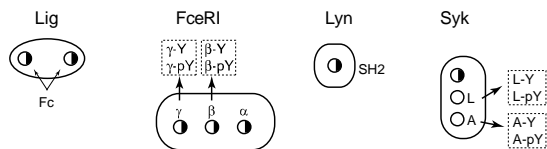

listOfSpecies

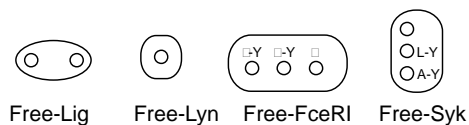

listOfObservables

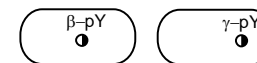

(b) listOfReactionRules

1. Ligand binding

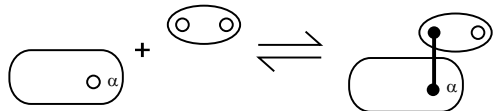

2. Ligand-induced aggregation



3. Binding of Lyn to unphosphorylated receptor

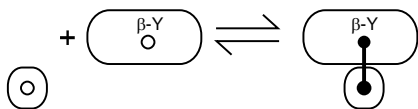

4. Binding of Lyn to phosphorylated receptor

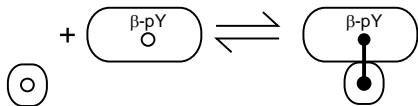

5. Transphosphorylation of β by Lyn

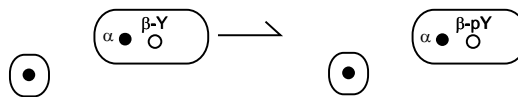

6. Transphosphorylation of γ by Lyn

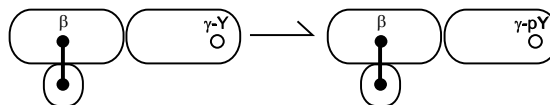

7. Binding of Syk to phosphorylated receptor

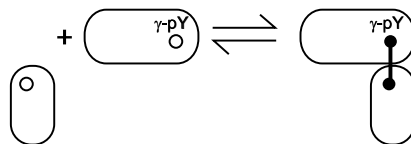

8. Transphosphorylation of Syk by Syk

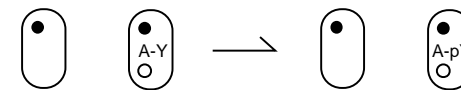

9. Transphosphorylation of Syk by Lyn

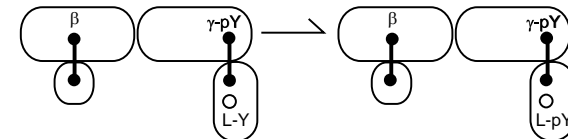

10. Dephosphorylation

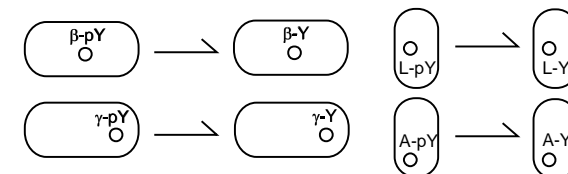

Graphical representation of molecules, their components and possible states of components:

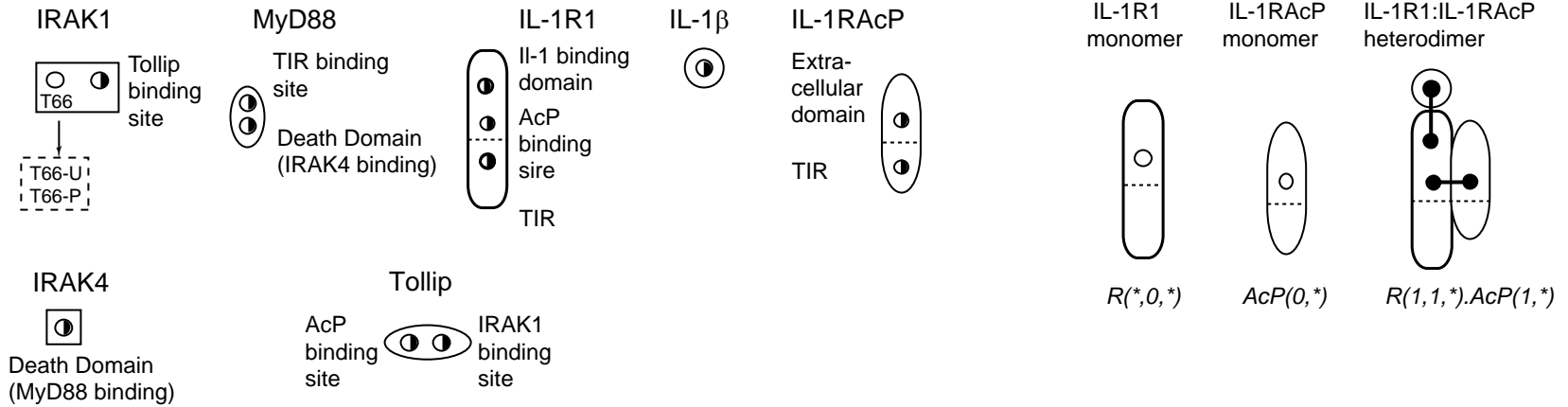

Reactions (103)

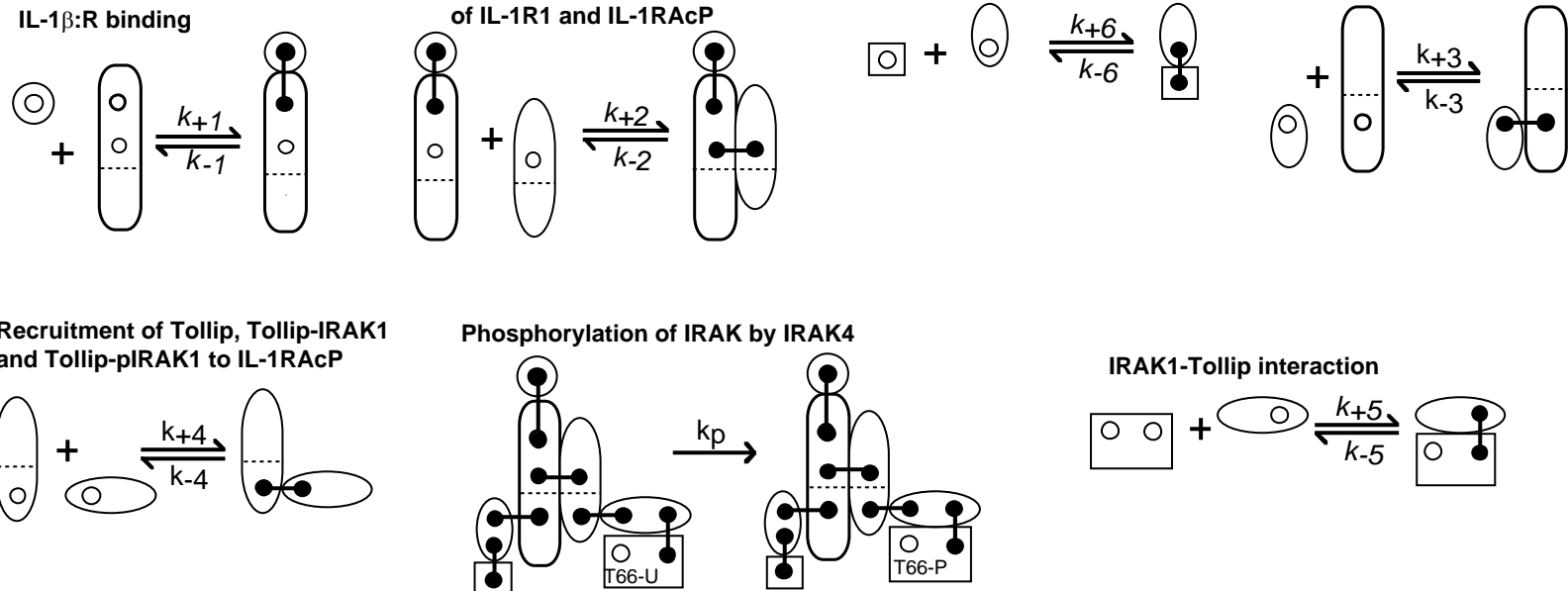

Graphical representation of molecules, their components and possible states of components:

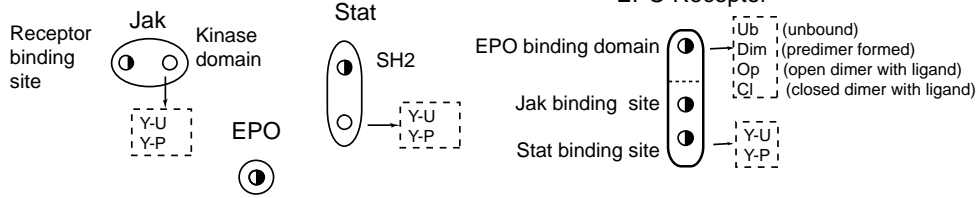

Groups of multistate species:

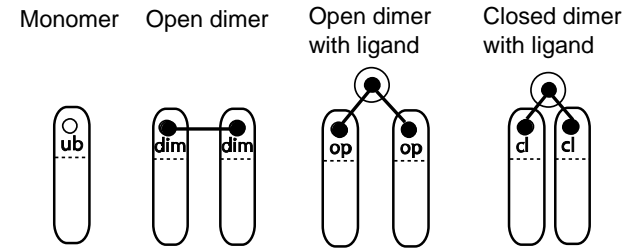

Reactions (1934 reactions)

