

# Putting state-variables on SBML entities

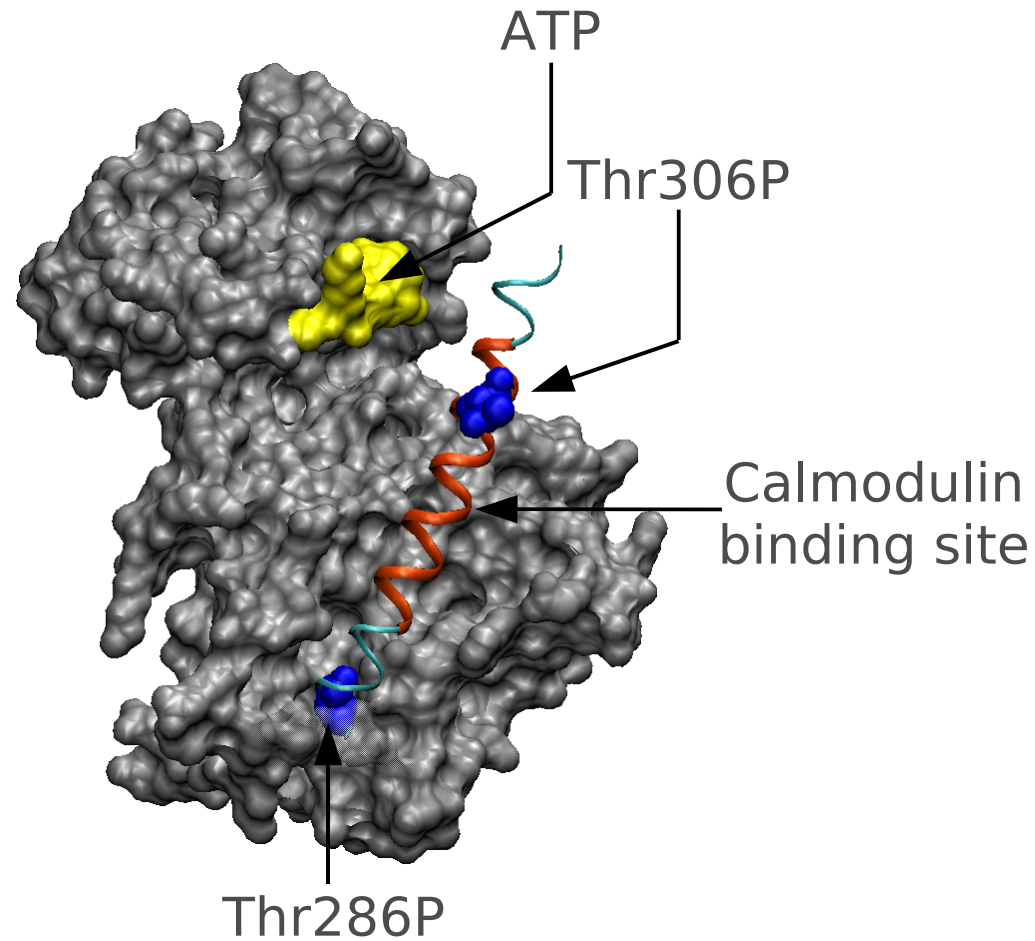

- The function of biological entities is modified by “internal” variables. For instance, function of macromolecules can depend on:
  - alternative conformations
  - covalent modifications
  - non-covalent binding
  - etc.
- The result is a combinatorial explosion of species and reactions
- We may want to track the values of the variables





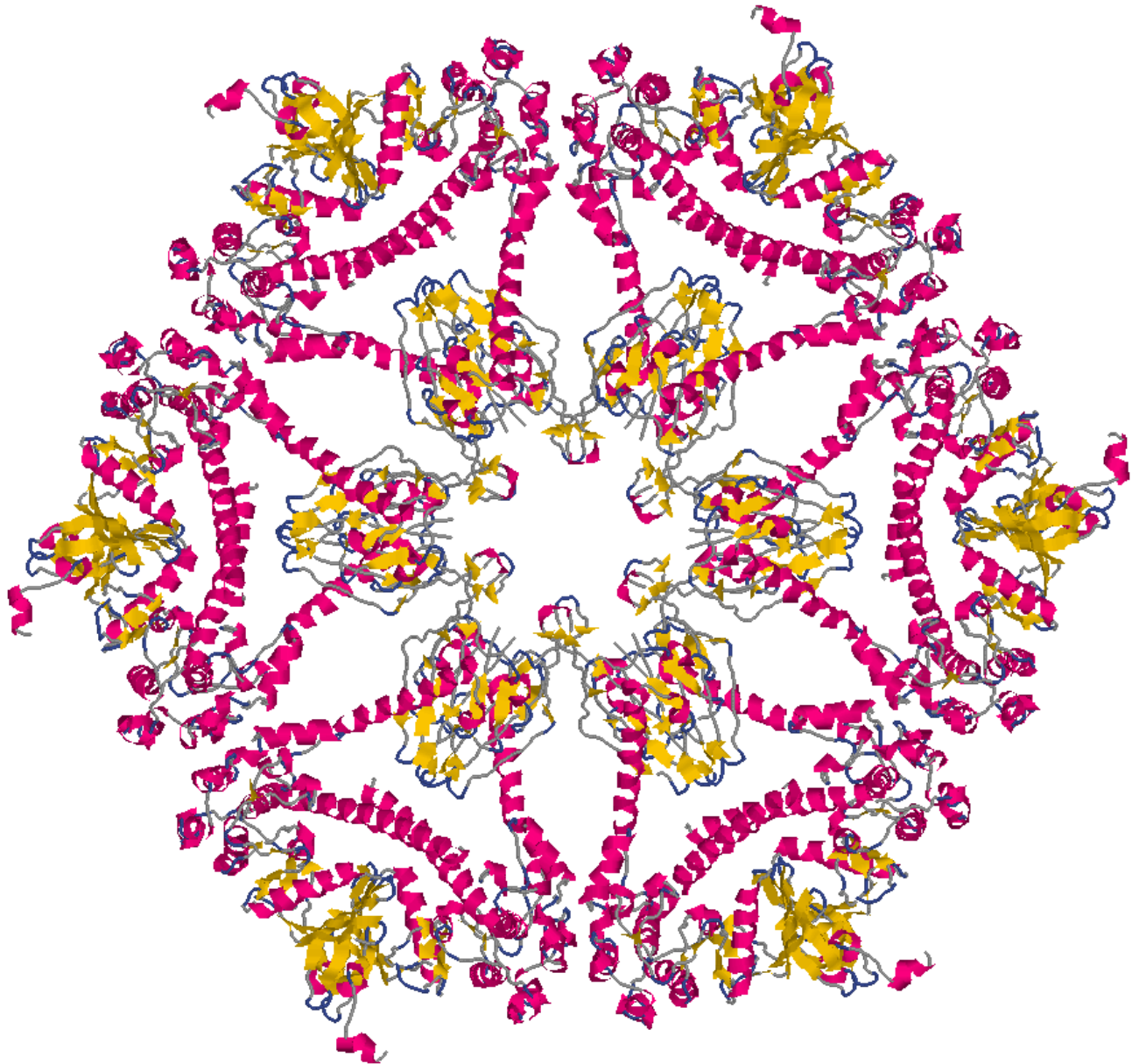

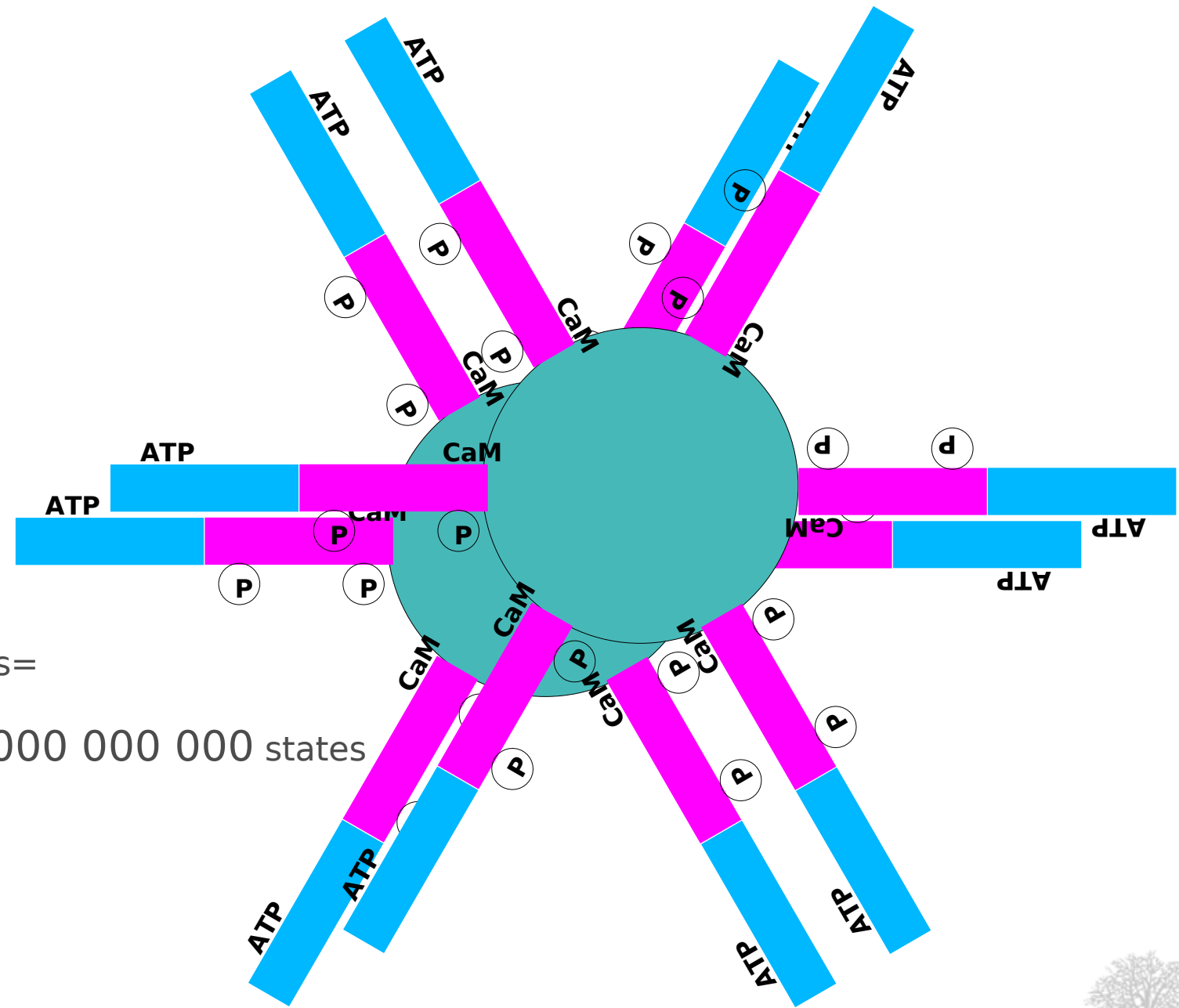

5x12 state variables=

1 152 900 000 000 000 000 000 states

(1 billion of billion)





- '?' Flags do not affect the reaction



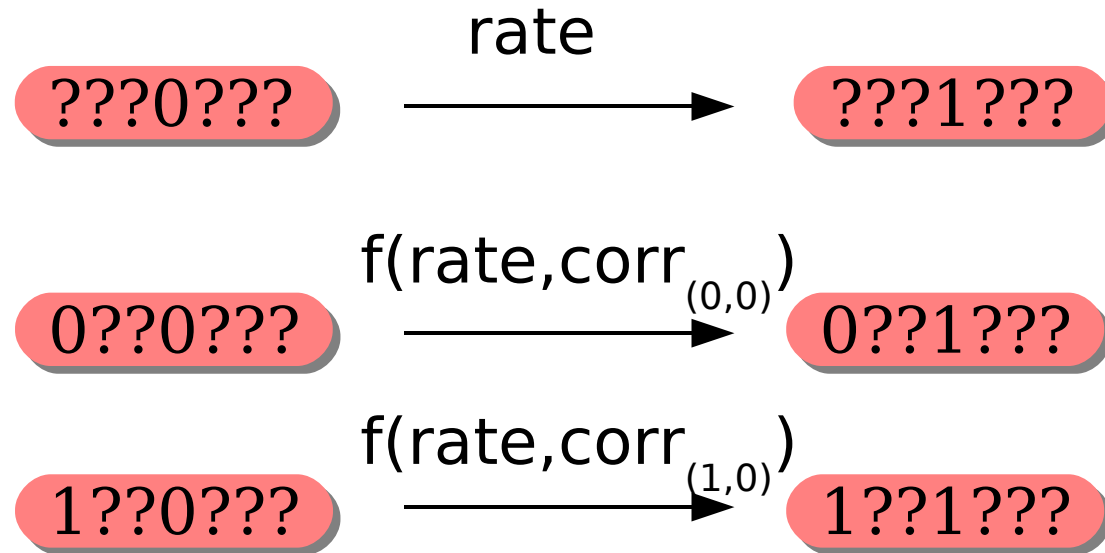

- '?' Flags do not affect the reaction
- only 4 species are needed instead of 128
- only 2 reactions are needed instead of 64



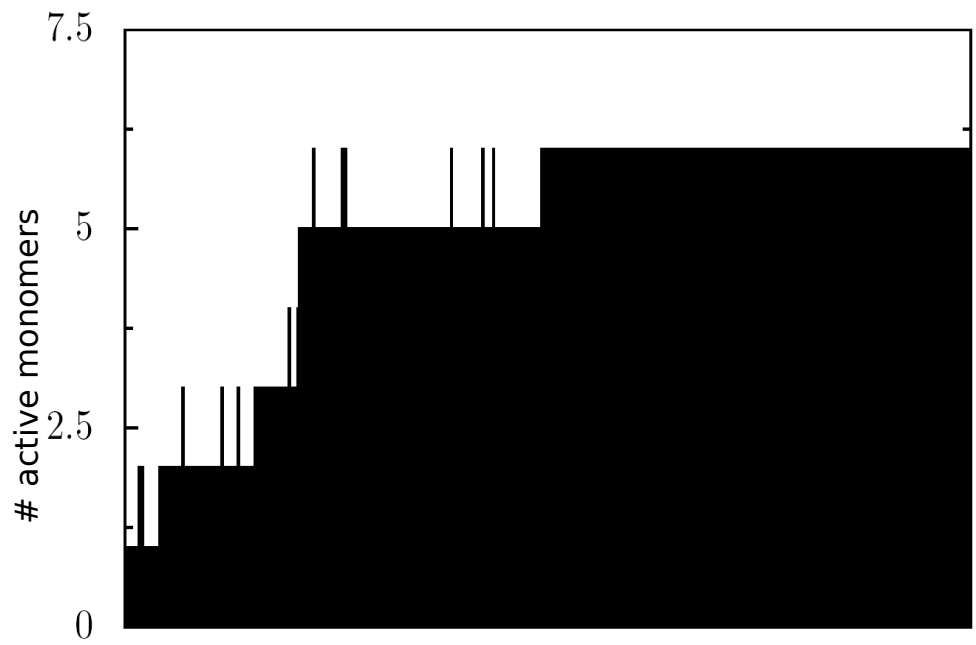
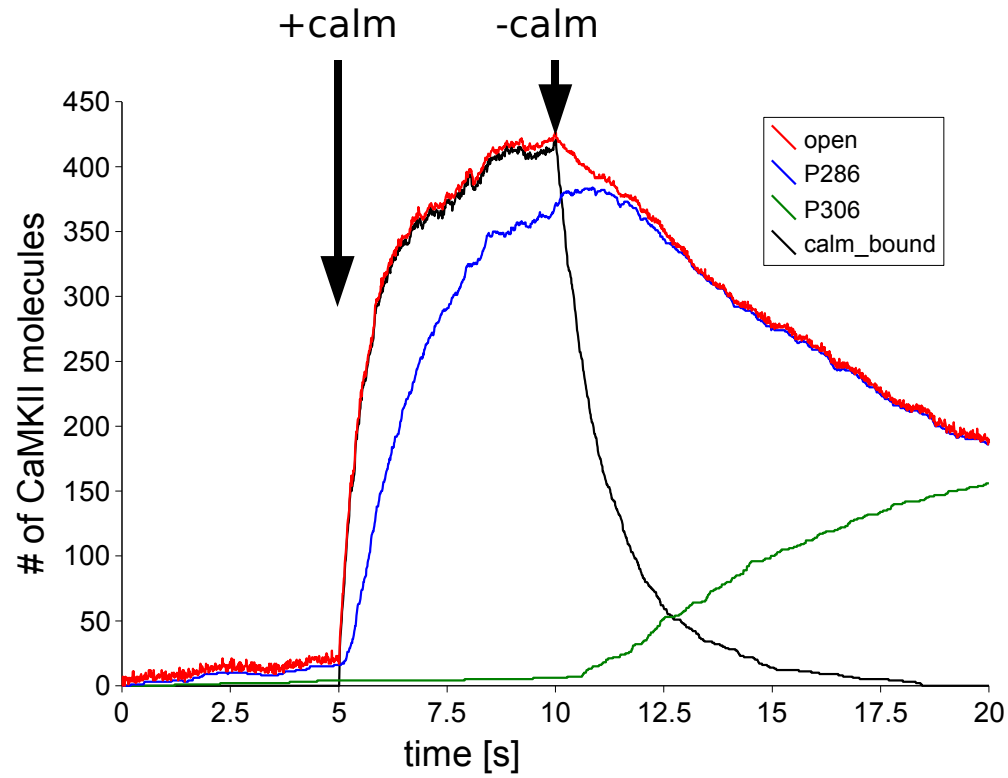

<http://www.ebi.ac.uk/compneur-srv/sbml/proposals/multistatesNEW.pdf>



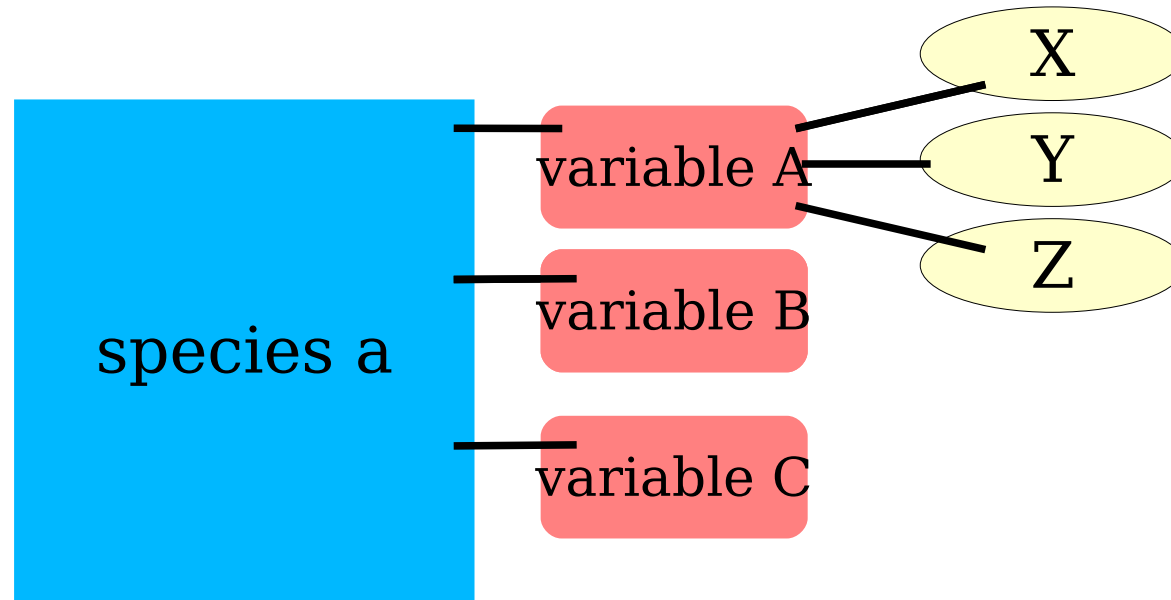

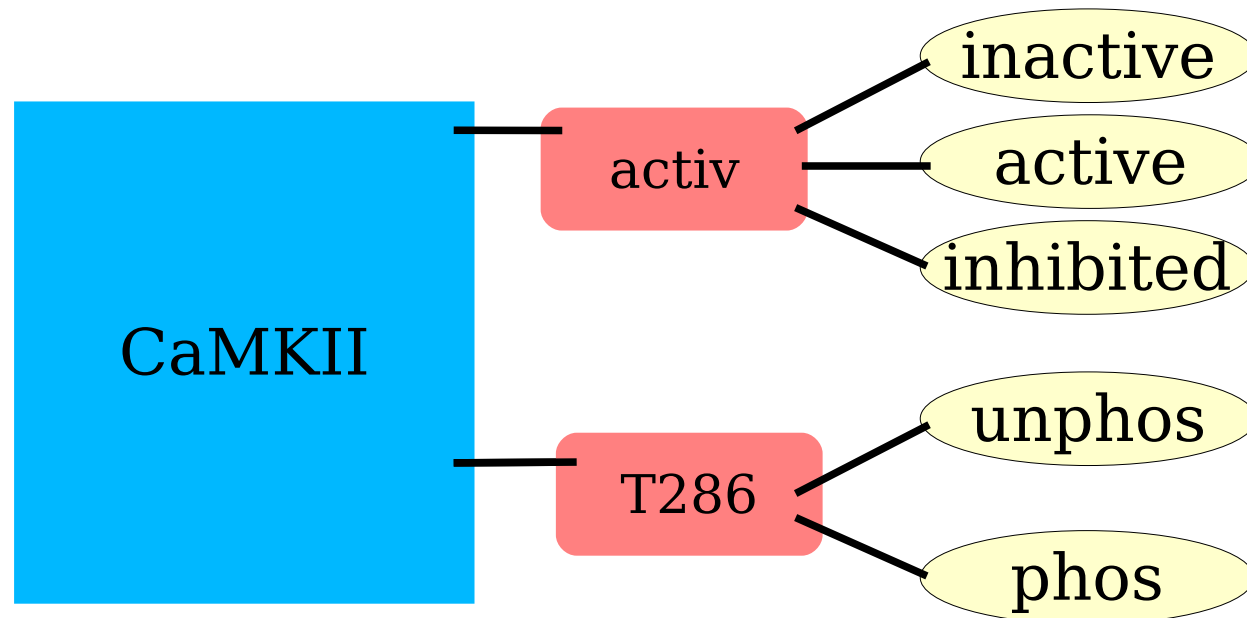

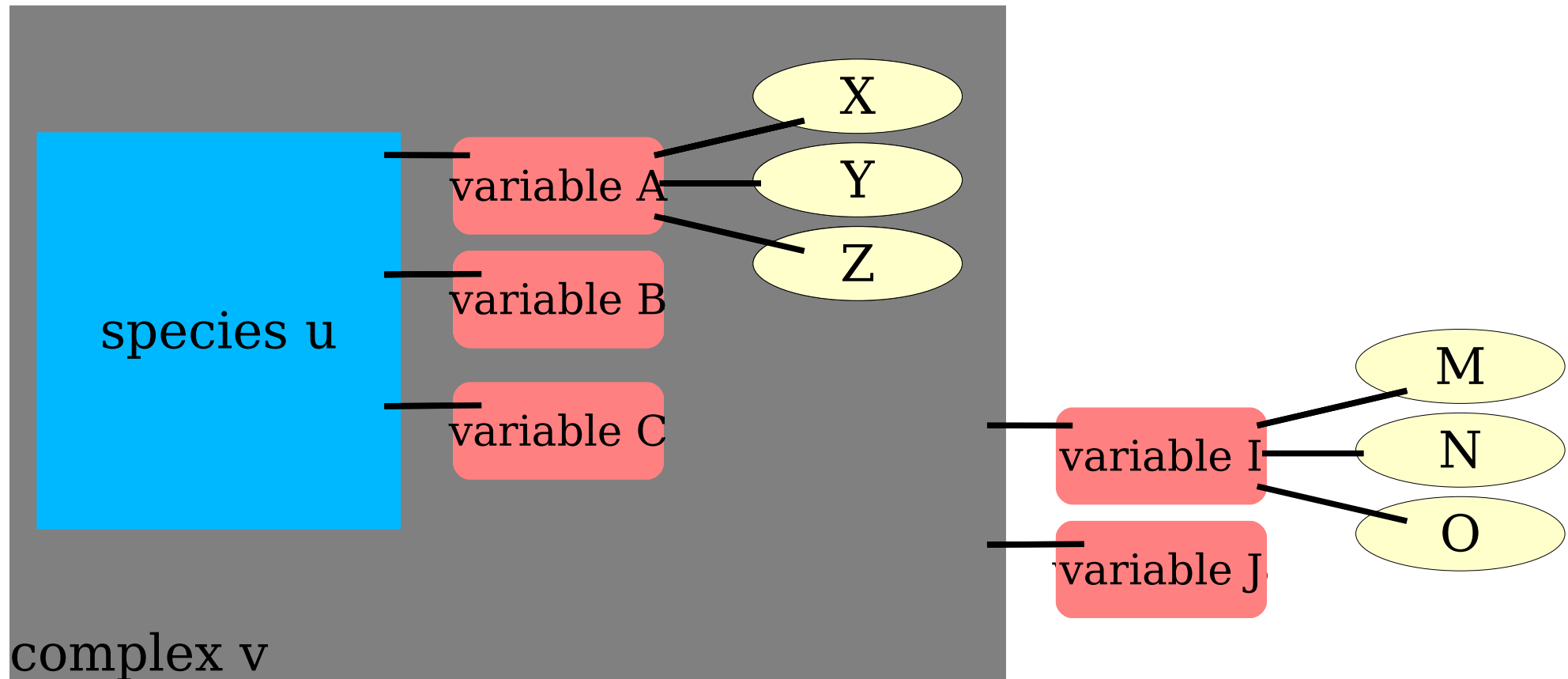

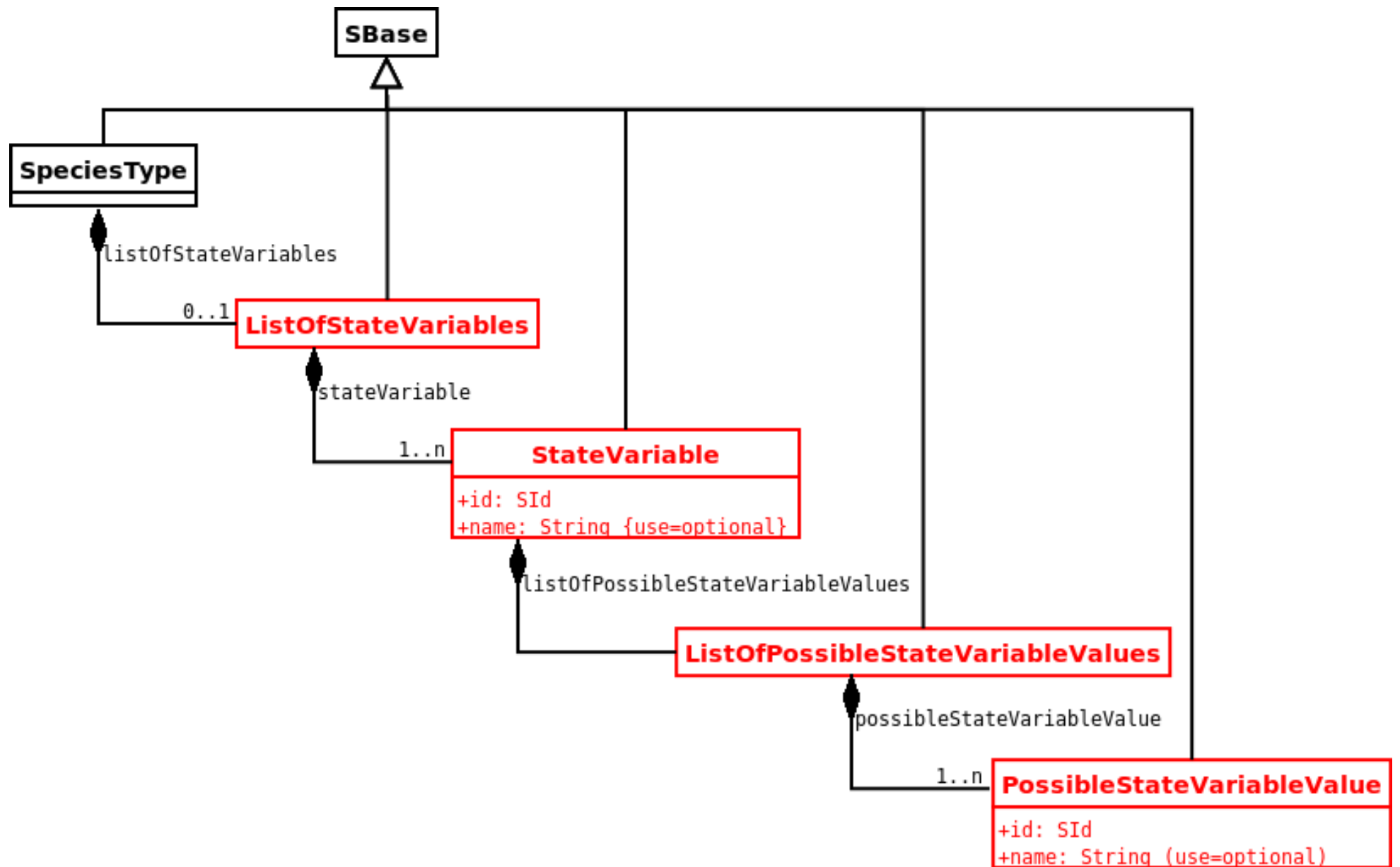

## Red is Level 2

```
<speciesType id="CaMKII" name="Calcium/Calmodulin Kinase II">
  <listOfStateVariables>
    <stateVariable id="activ" name="activity">
      <listOfPossibleStateVariableValues>
        <possibleStateVariableValue id="inact" name="inactive" />
        <possibleStateVariableValue id="act" name="active" />
        <possibleStateVariableValue id="inhib" name="inhibited"/>
      </listOfPossibleStateVariableValues>
    </stateVariable>
    <stateVariable id="T286" name="threonine 286">
      <listOfPossibleStateVariableValues>
        <possibleStateVariableValue id="unphos" name="non-phosphorylated"/>
        <possibleStateVariableValue id="phos" name="phosphorylated" />
      </listOfPossibleStateVariableValues>
    </stateVariable>
  </listOfStateVariables>
</speciesType>
```



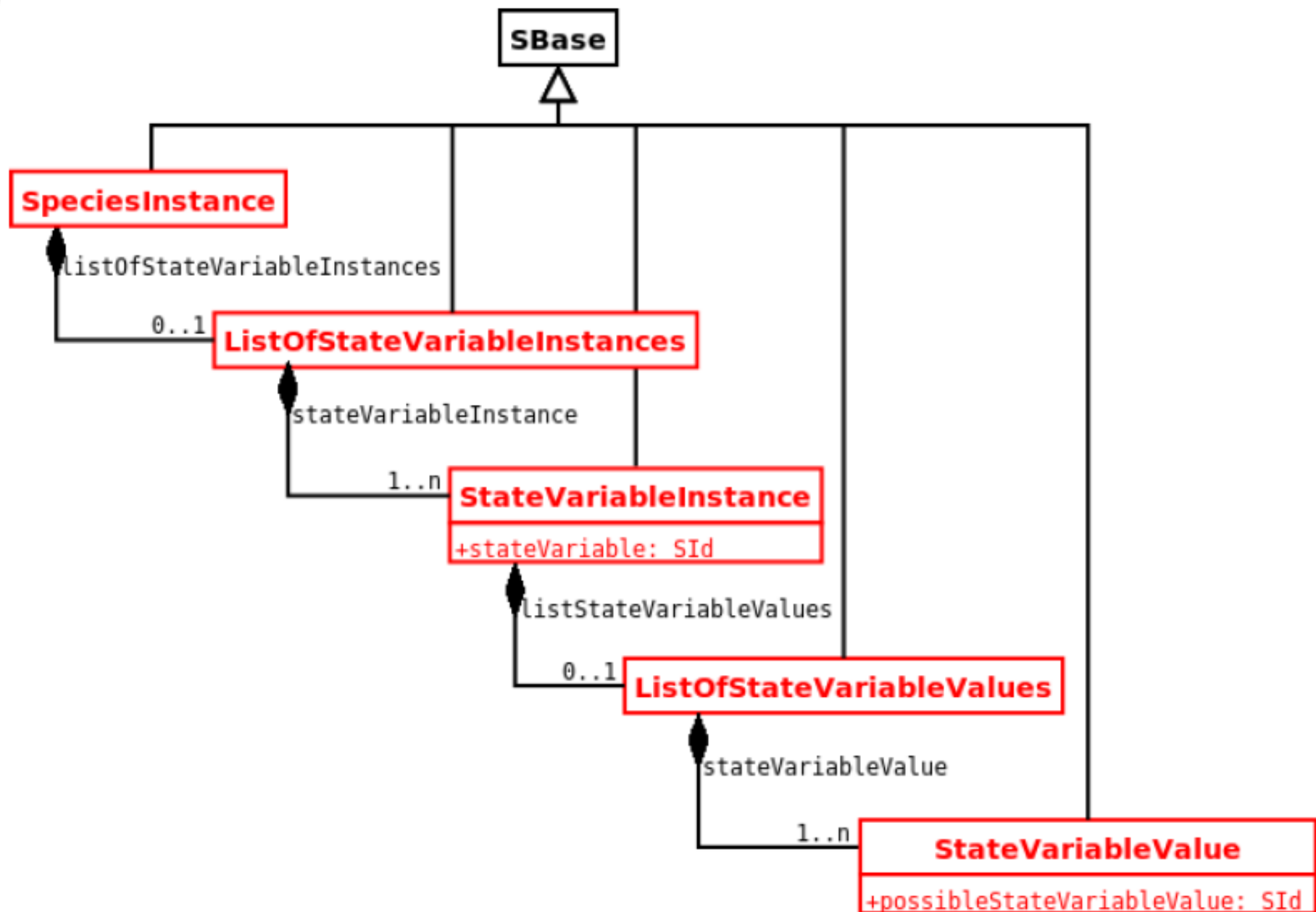

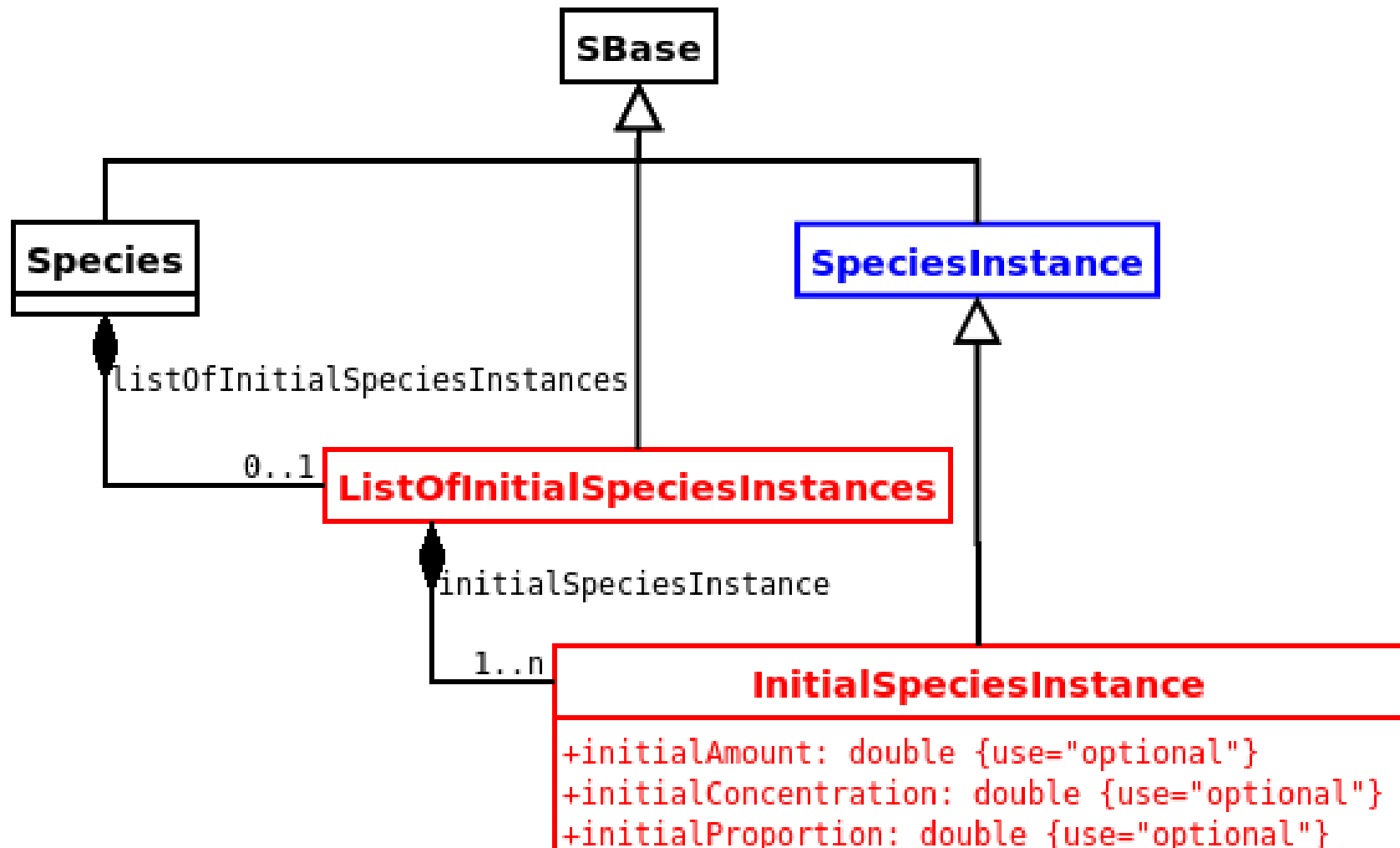

```
<species id="K_PSD" name="CaMKII in postsynaptic density"
  speciesType="CaMKII" compartment="PSD" initialAmount="500">
  <listOfInitialSpeciesInstances>
    <initialSpeciesInstance initialProportion="0.9" >
      <listOfStateVariableInstances>
        <stateVariableInstance stateVariable="activ" >
          <listOfStateVariableValues>
            <stateVariableValue possibleStateVariableValue="inact" />
          </listOfStateVariableValues>
        </stateVariableInstance>
        <stateVariableInstance stateVariable="T286" >
          <listOfStateVariableValues>
            <stateVariableValue possibleStateVariableValue="unphos" />
          </listOfStateVariableValues>
        </stateVariableInstance>
      </listOfStateVariableInstances>
    </initialSpeciesInstance>
    <initialSpeciesInstance initialProportion="0.1" >
      <listOfStateVariableInstances>
        <stateVariableInstance stateVariable="activ" >
          <listOfStateVariableValues>
            <stateVariableValue possibleStateVariableValue="act" />
          </listOfStateVariableValues>
        </stateVariableInstance>
        <stateVariableInstance stateVariable="T286" >
          <listOfStateVariableValues>
            <stateVariableValue possibleStateVariableValue="unphos" />
          </listOfStateVariableValues>
        </stateVariableInstance>
      </listOfStateVariableInstances>
    </initialSpeciesInstance>
  </listOfInitialSpeciesInstances>
</species>
```



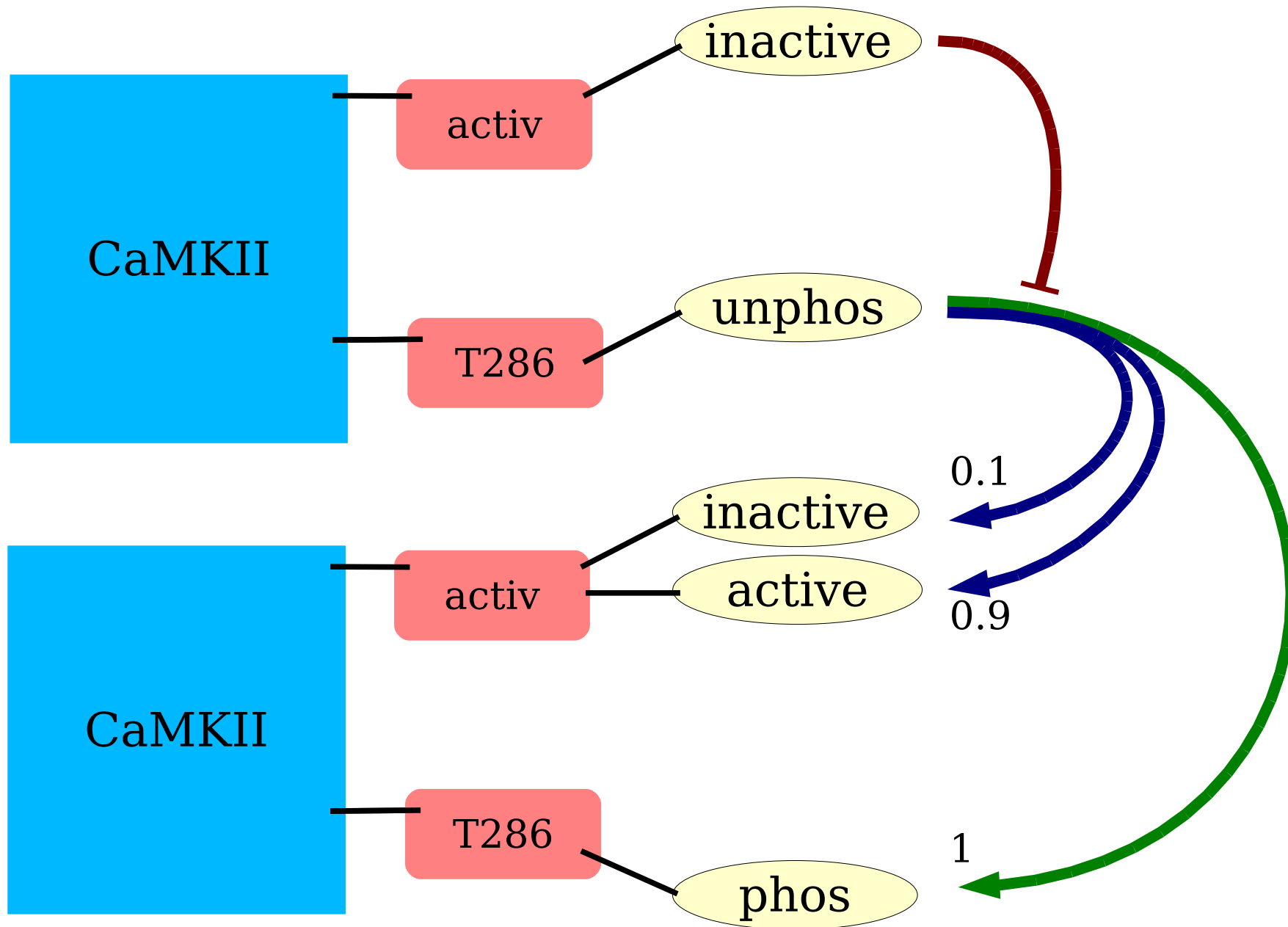

```
<reaction id="rPhosp">
  <listOfReactants>
    <speciesReference species="K_PSD">
      ...
    </speciesReference>
  </listOfReactants>
  <listOfProducts>
    <speciesReference species="K_PSD">
      ...
    </speciesReference>
  </listOfProducts>
  <kineticLaw>
    <math
xmlns="http://www.w3.org/1998/Math/MathML">
      <apply>
        <times/>
        <ci>kon</ci>
        <ci>K_PSD</ci>
        <ci>cell</ci>
      </apply>
    </math>
  </kineticLaw>
</reaction>
```



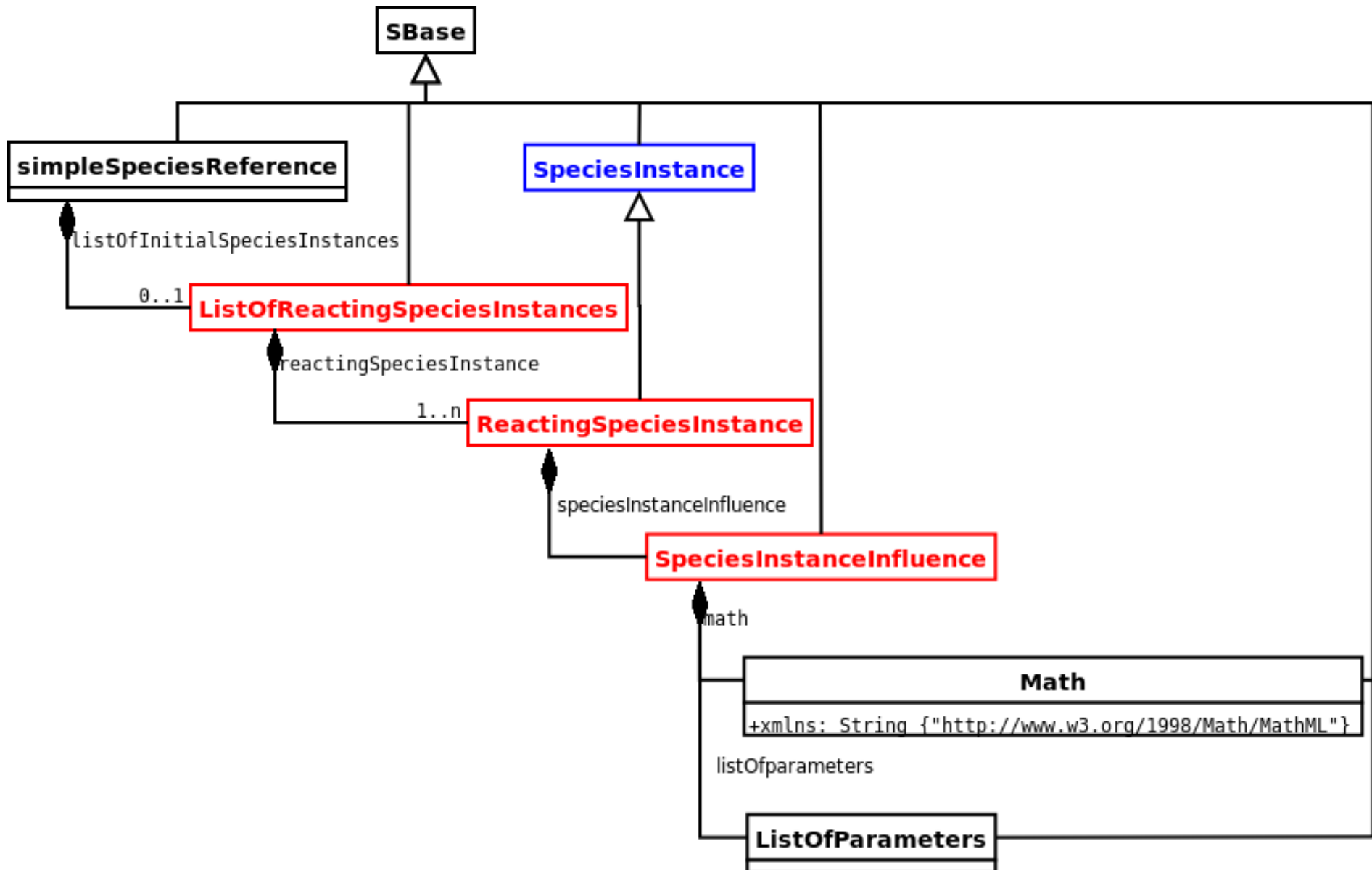

```
<listOfReactants>
  <speciesReference species="K_PSD">
    <listOfReactingSpeciesInstances>
      <reactingSpeciesInstance>
        <listOfStateVariableInstances>
          <stateVariableInstance stateVariable="activ" >
            <listOfStateVariableValues>
              <stateVariableValue possibleStateVariableValue="inact" />
            </listOfStateVariableValues>
          </stateVariableInstance>
          <stateVariableInstance stateVariable="T286" >
            <listOfStateVariableValues>
              <stateVariableValue possibleStateVariableValue="unphosp" />
            </listOfStateVariableValues>
          </stateVariableInstance>
        </listOfStateVariableInstances>
        <speciesInstanceInfluence>
          <math xmlns="http://www.w3.org/1998/Math/MathML">
            <apply>
              <times/>
              <ci>rPhosp</ci>
              <ci>Prel</ci>
            </apply>
          </math>
          <listOfParameters>
            <parameter id="Prel" value="0">
          </listOfParameters>
        </speciesInstanceInfluence>
      </reactingSpeciesInstance>
    </listOfReactingSpeciesInstances>
  </speciesReference>
</listOfReactants>
```



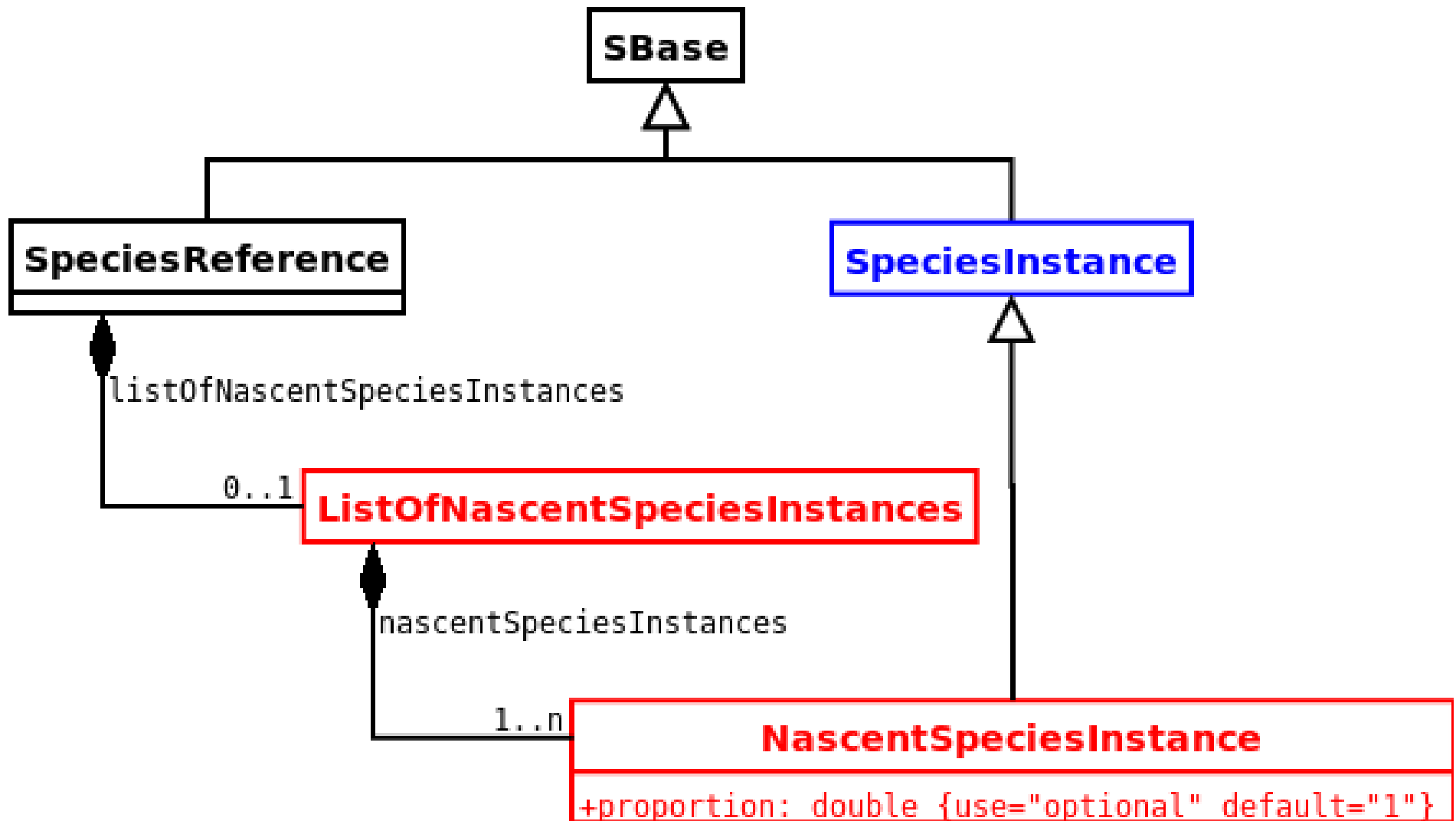

```
<listOfProducts>
  <speciesReference species="K_PSD">
    <listOfNascentSpeciesInstances>
      <nascentSpeciesInstance proportion="0.9">
        <listOfStateVariableInstances>
          <stateVariableInstance stateVariable="activ" >
            <listOfStateVariableValues>
              <stateVariableValue possibleStateVariableValue="act" />
            </listOfStateVariableValues>
          </stateVariableInstance>
          <stateVariableInstance stateVariable="T286" >
            <listOfStateVariableValues>
              <stateVariableValue possibleStateVariableValue="phosp" />
            </listOfStateVariableValues>
          </stateVariableInstance>
        </listOfStateVariableInstances>
      </nascentSpeciesInstance>
      <nascentSpeciesInstance proportion="0.1">
        <listOfStateVariableInstances>
          <stateVariableInstance stateVariable="activ" >
            <listOfStateVariableValues>
              <stateVariableValue possibleStateVariableValue="inact" />
            </listOfStateVariableValues>
          </stateVariableInstance>
          <stateVariableInstance stateVariable="T286" >
            <listOfStateVariableValues>
              <stateVariableValue possibleStateVariableValue="phosp" />
            </listOfStateVariableValues>
          </stateVariableInstance>
        </listOfStateVariableInstances>
      </nascentSpeciesInstance>
    </listOfNascentSpeciesInstances>
  </speciesReferenc>
</listOfProducts>
```



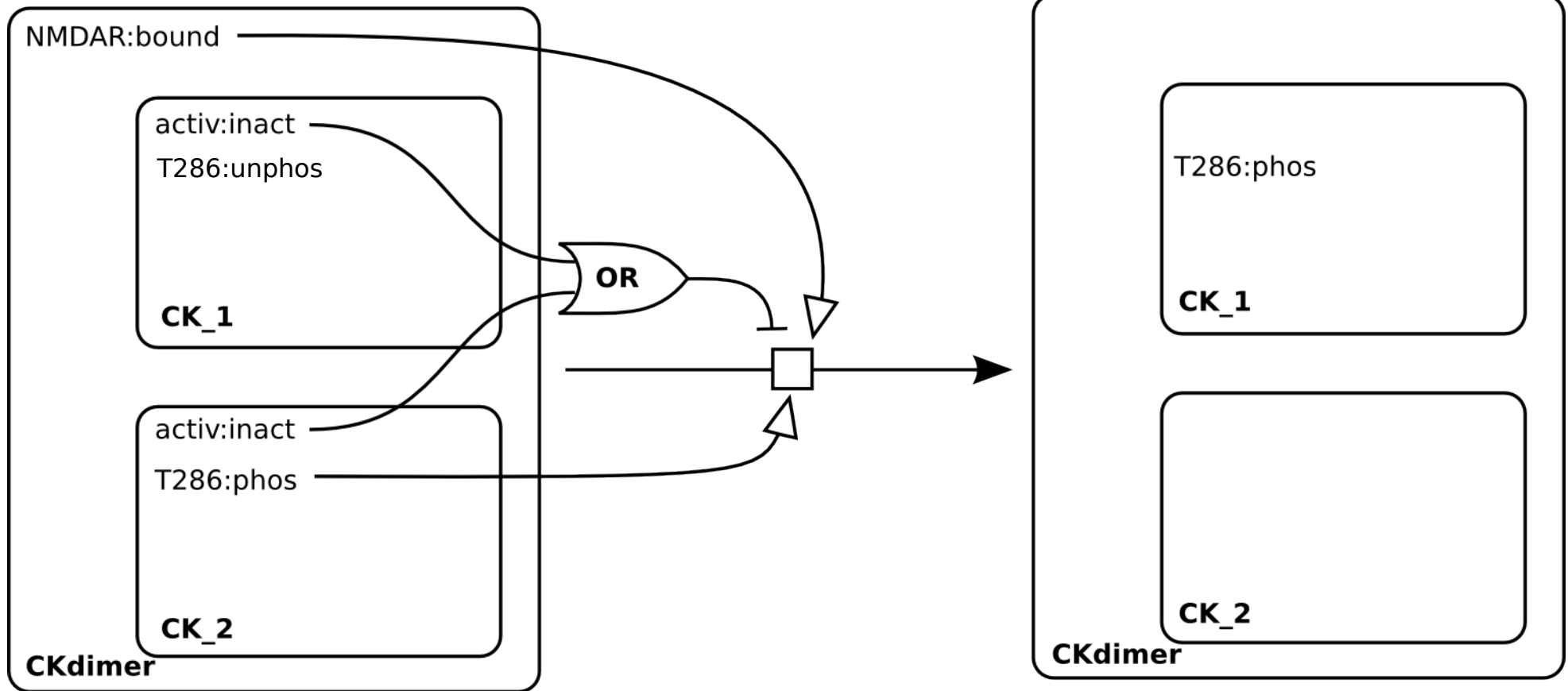

- Reduced version in proprietary annotation in StochSim's namespace: Fork of SBMLeditor as StochSim SBML import.
- Complete version of the extension will be added to “regular” SBMLeditor, to benchmark it.

