

Logical modelling of biological regulatory networks

Contents

- Introduction
- Logical modelling of regulatory networks
- Development of novel computational tools
- Applications

Biological regulatory networks

Abstraction levels *versus* biological questions:

- Molecular level: biochemical networks, signal transduction
- **Genetic level: genetic regulatory networks**
- Inter-cellular level: cell differentiation, tissues, patterns
- Macroscopic levels (organs, physiology...)

Dynamical modelling of biological regulatory systems

Why ?

- To gain rigorous, global, functional understanding
- To predict the behaviour of the system in novel situations
- To design novel experiments

How ?

- Regulatory charts/maps/graphs
- Qualitative modelling: **Boolean/logical models**, **Petri nets**
- Quantitative modelling: ODE, PDE, Stochastic equations

Logical modelling of regulatory networks

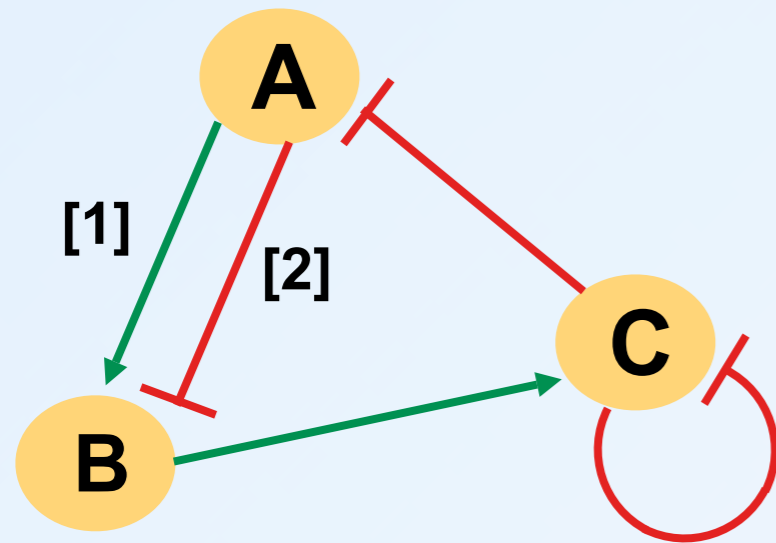

- ✓ A **graph** describes the interactions between genes or regulatory products
- ✓ **Discrete levels** of expression associated to each regulatory component and interaction

✓ Logical rules/parameters

✓ $K_A = 2$ IFF $(C=0)$
 $K_B = 0$ otherwise

✓ $K_B = 1$ IFF $(A=1)$
 $K_C = 0$ otherwise

✓ $K_C = 1$ IFF $(B=1)$ AND $(C=0)$

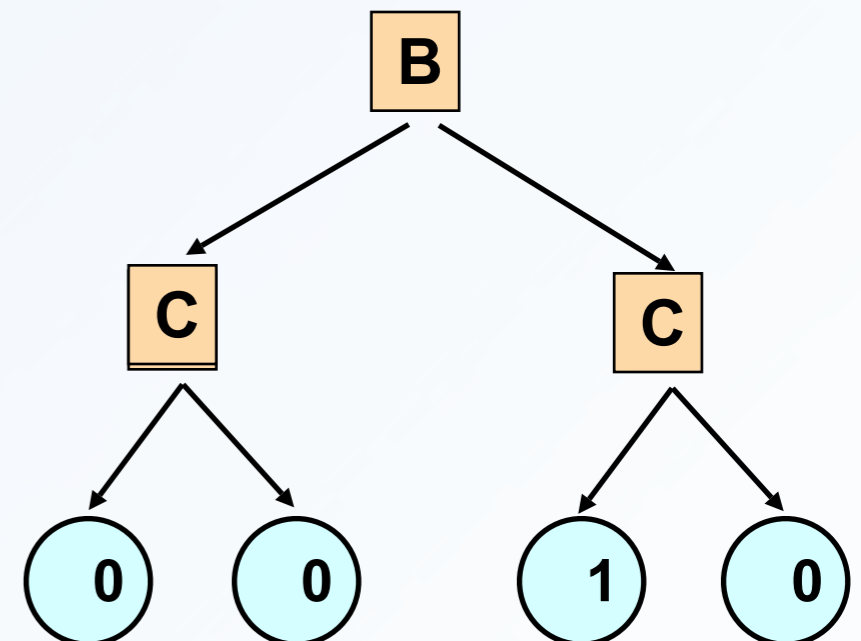
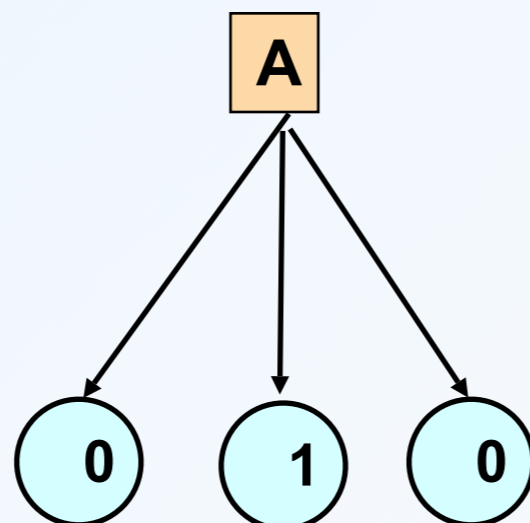
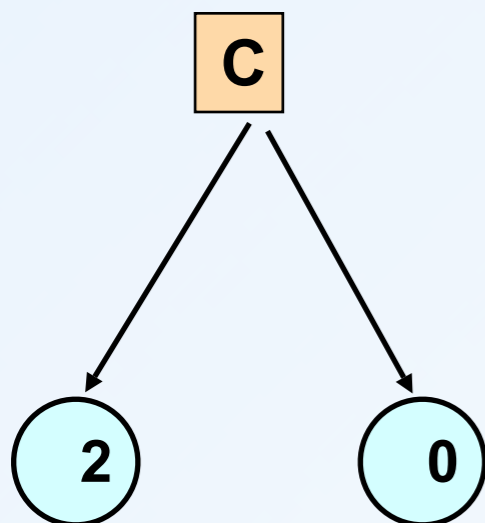

Logical modelling of regulatory networks

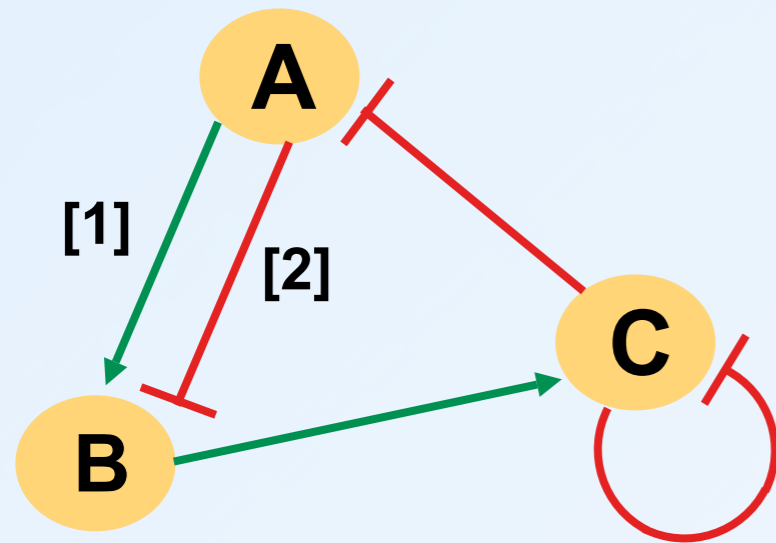

- ✓ A **graph** describes the interactions between genes or regulatory products
- ✓ **Discrete levels** of expression associated to each regulatory component and interaction

✓ Logical rules/parameters

✓ $K_A = 2$ IFF $(C=0)$
 $K_B = 0$ otherwise

✓ $K_B = 1$ IFF $(A=1)$
 $K_C = 0$ otherwise

✓ $K_C = 1$ IFF $(B=1)$ AND $(C=0)$

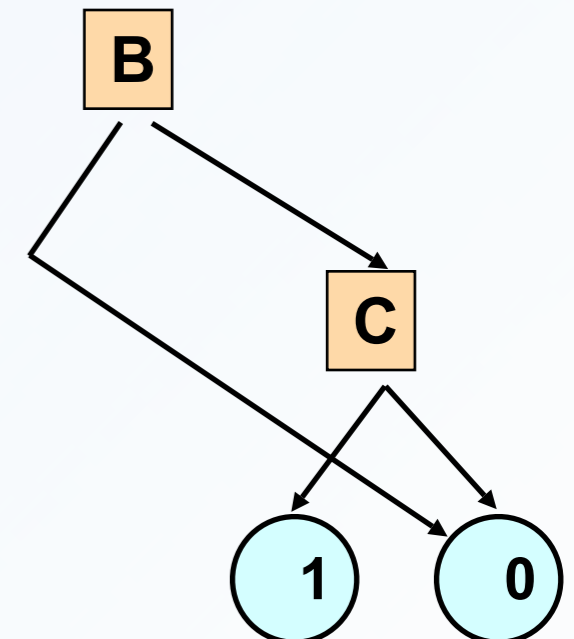
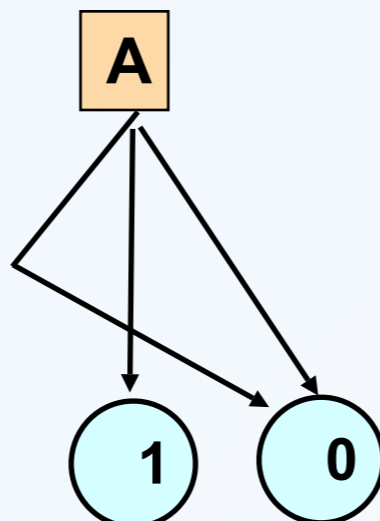
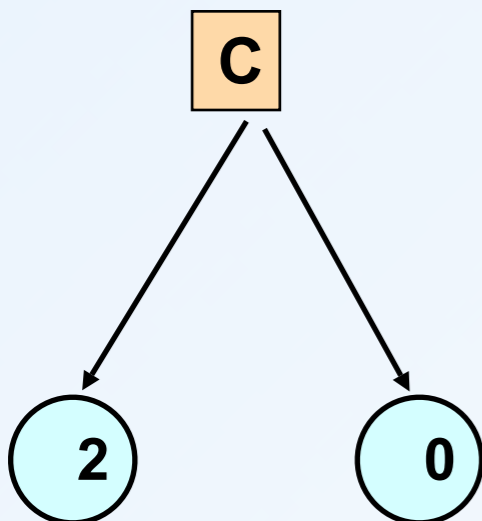

Logical state transition graphs

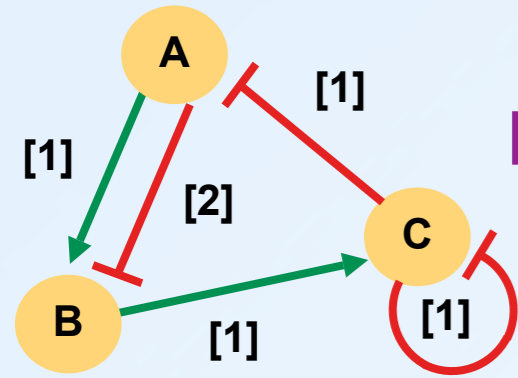

Regulatory graph + Logical rules \Rightarrow state transition graphs

Asynchronous updating

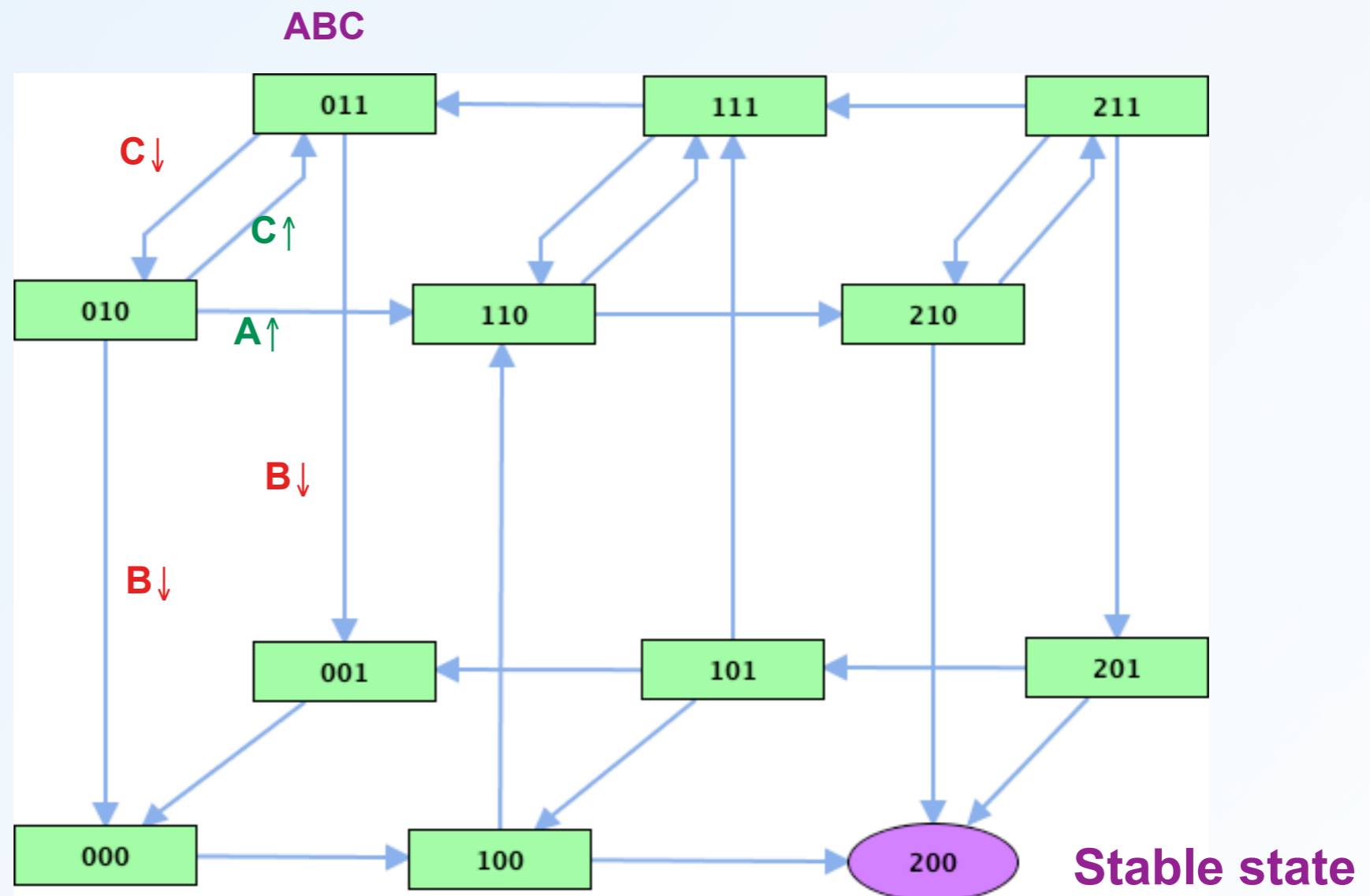

Logical state transition graphs

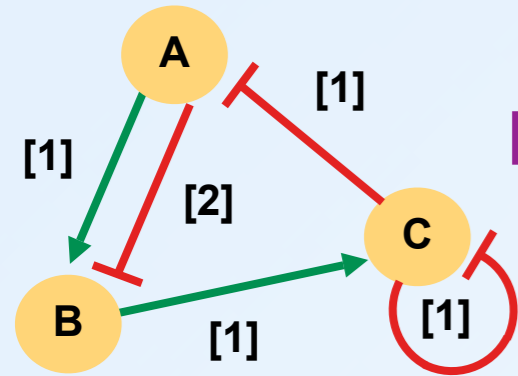

Regulatory graph + Logical rules \Rightarrow state transition graphs

Synchronous updating

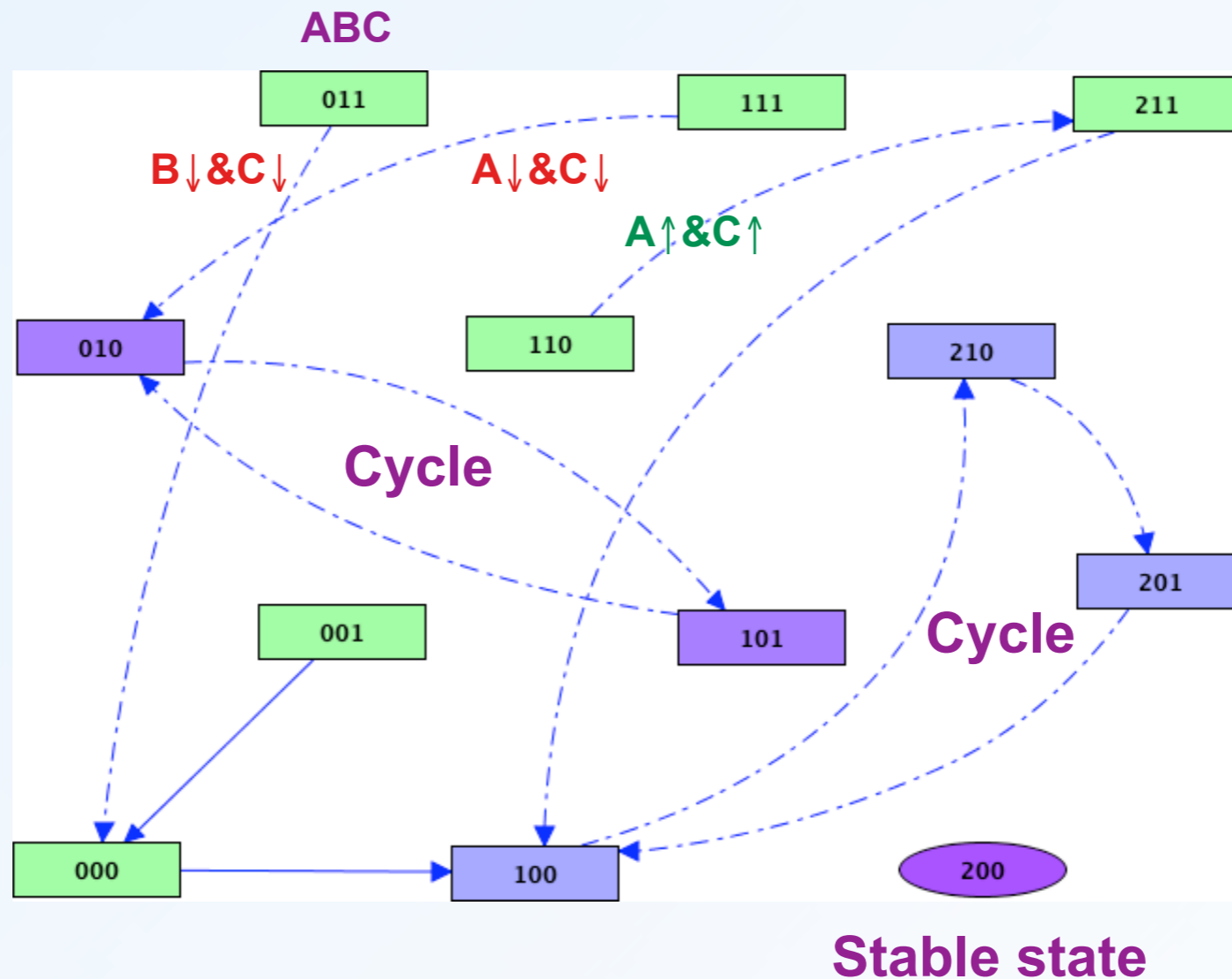

GINsim (Gene Interaction Networks simulation)

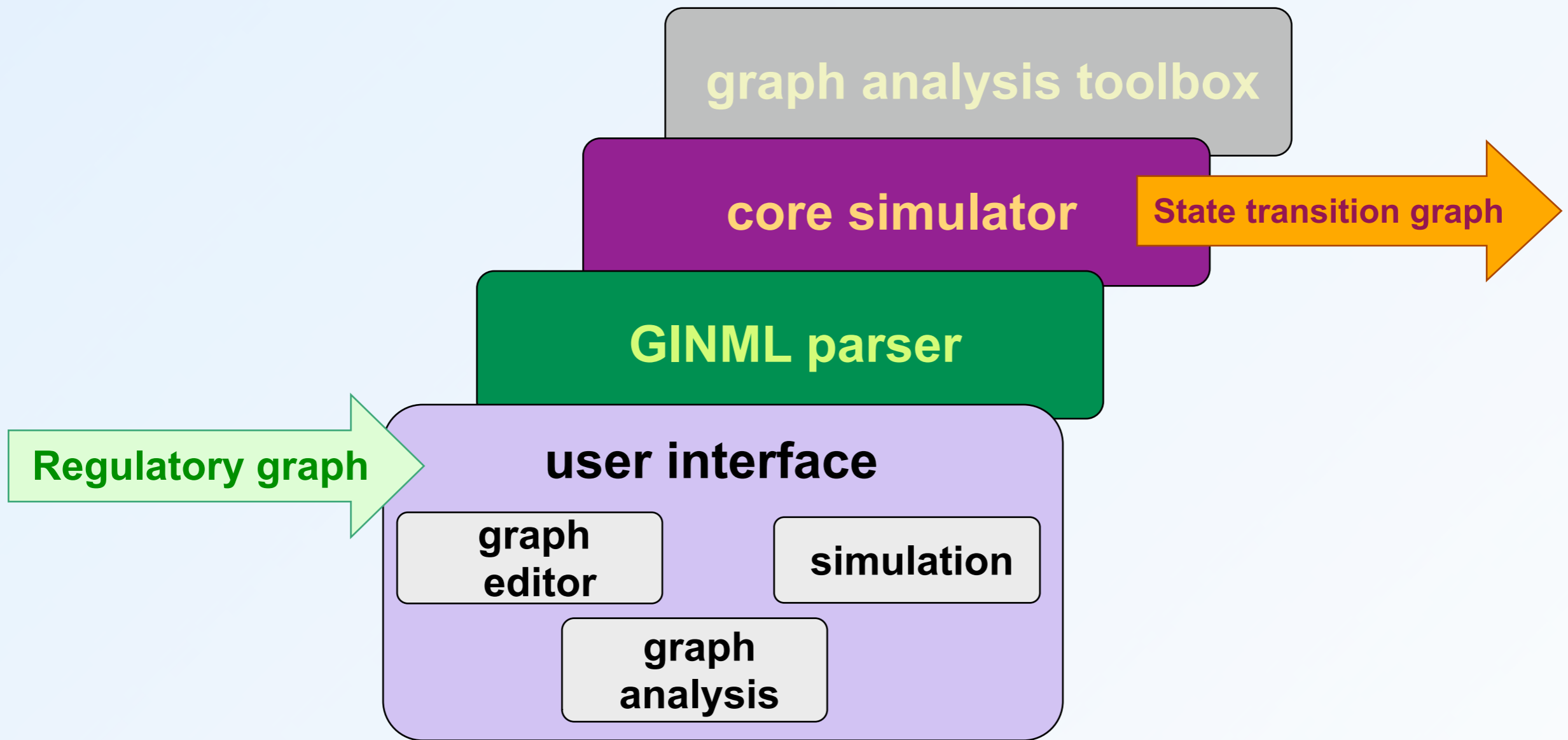

Available at <http://gin.univ-mrs.fr/GINsim>

Development of novel computational tools

- **Decision diagrams (Aurélien NALDI)** [LNCS 4695 (2007): 233-47]
 - Identification of stable states
 - Analysis of feedback circuits
- **Model reduction and composition (Aurélien NALDI)**
- **Priorities**
 - Mixed a/synchronous simulations [Fauré *et al* (2006) *Bioinformatics* **22**: e124-31]
- **Translation into Petri nets (Claudine CHAOUIYA)**
 - Standard Petri nets [Remy *et al* (2006). LNCS **4230**: 56-72]
 - Coloured Petri nets [Chaouiya *et al* (2006) LNCS **4220**: 95-112]
- **Logical programming (Fabien CORBLIN, François FAGES)**
 - Attractor identification and reachability analysis

Applications

■ **Drosophila development**

- Genetic control of segmentation (L Sanchez, CIB, Madrid)
- Compartment formation in imaginal disks (A Gonzalez)
- Mesoderm, muscle and heart development (E Furlong, EMBL)

■ **Cell cycle (DIAMONDS, FP6)**

- Yeast (*S. cerevisiae*) (A Fauré ; A Ciliberto, IFOM, Milano)
- Mammalian cell proliferation (O Sahin , H Froehlich & T Beissbarth, DKFZ, Heidelberg ; L Calzone, A Zynoviev, E Barillot, Institut Curie, Paris)
- Drosophila (endocycles, syncytial cycles) (L Calzone, B Novak, J Tyson)

■ **T cell differentiation, activation and proliferation**

- Differentiation: Th lymphoid lineages (A Naldi ; J Carneiro, IGC)
- TCR signalling
- Hematopoietic differentiation (T Graf & L Serrano, CRG, Barcelona)

■ **Apoptosis (APO-SYS, FP7)**

Early mesoderm specification in *Drosophila*

(with E Furlong, EMBL, Heidelberg)

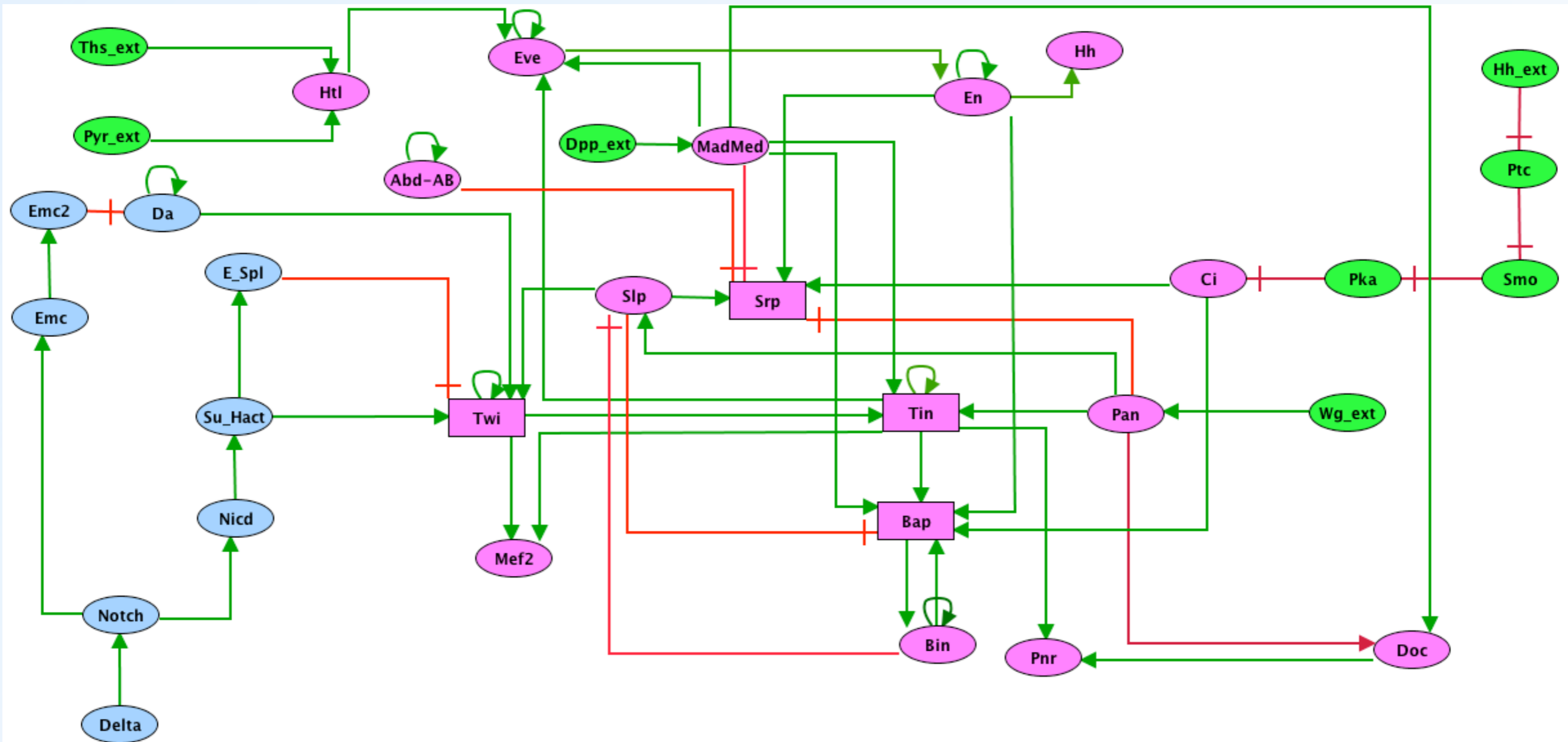

Early hematopoiesis specification

(with T. Graf, CRG, Barcelona)

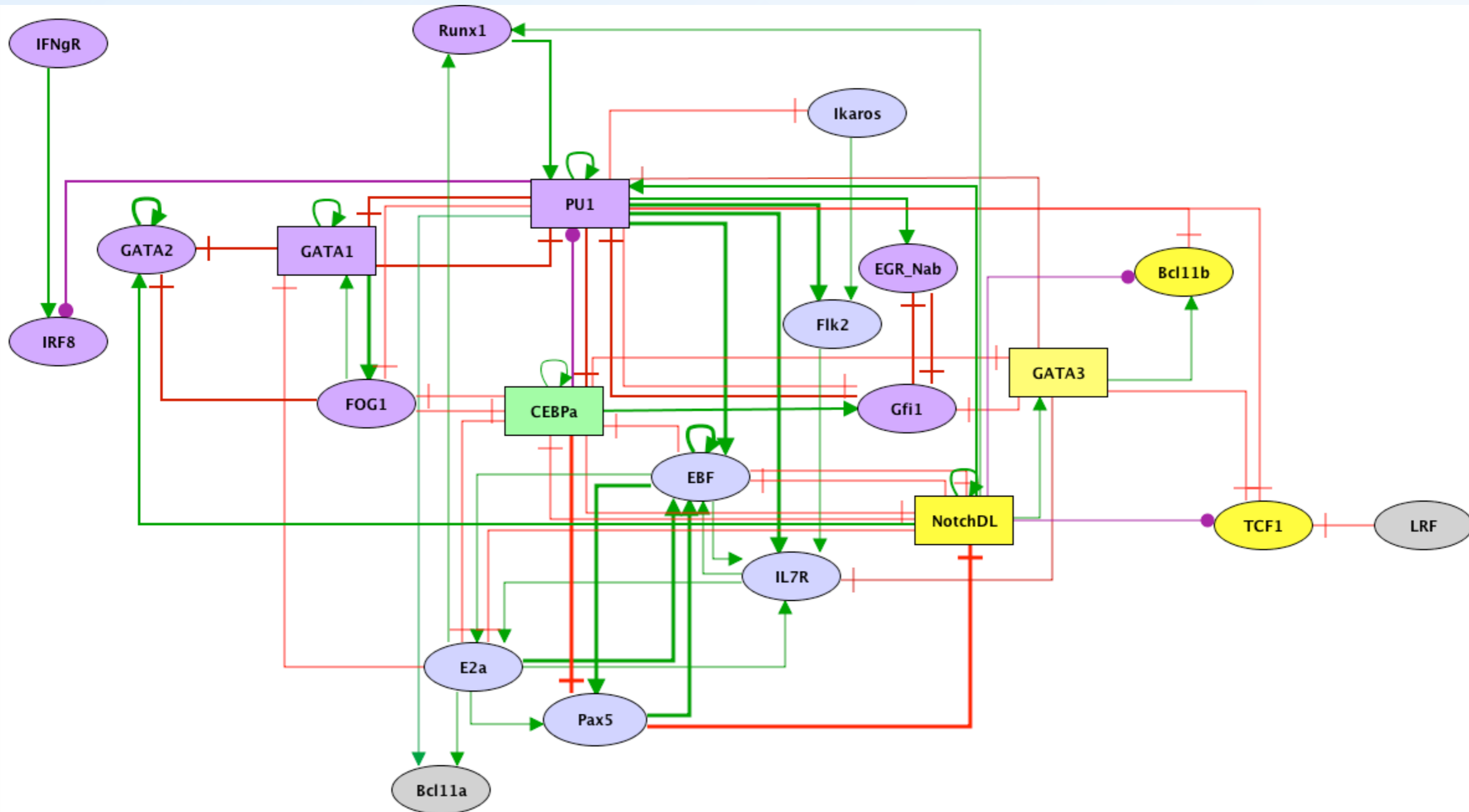

T lymphocyte differentiation

(with J Carneiro, IGC, Oeiras)

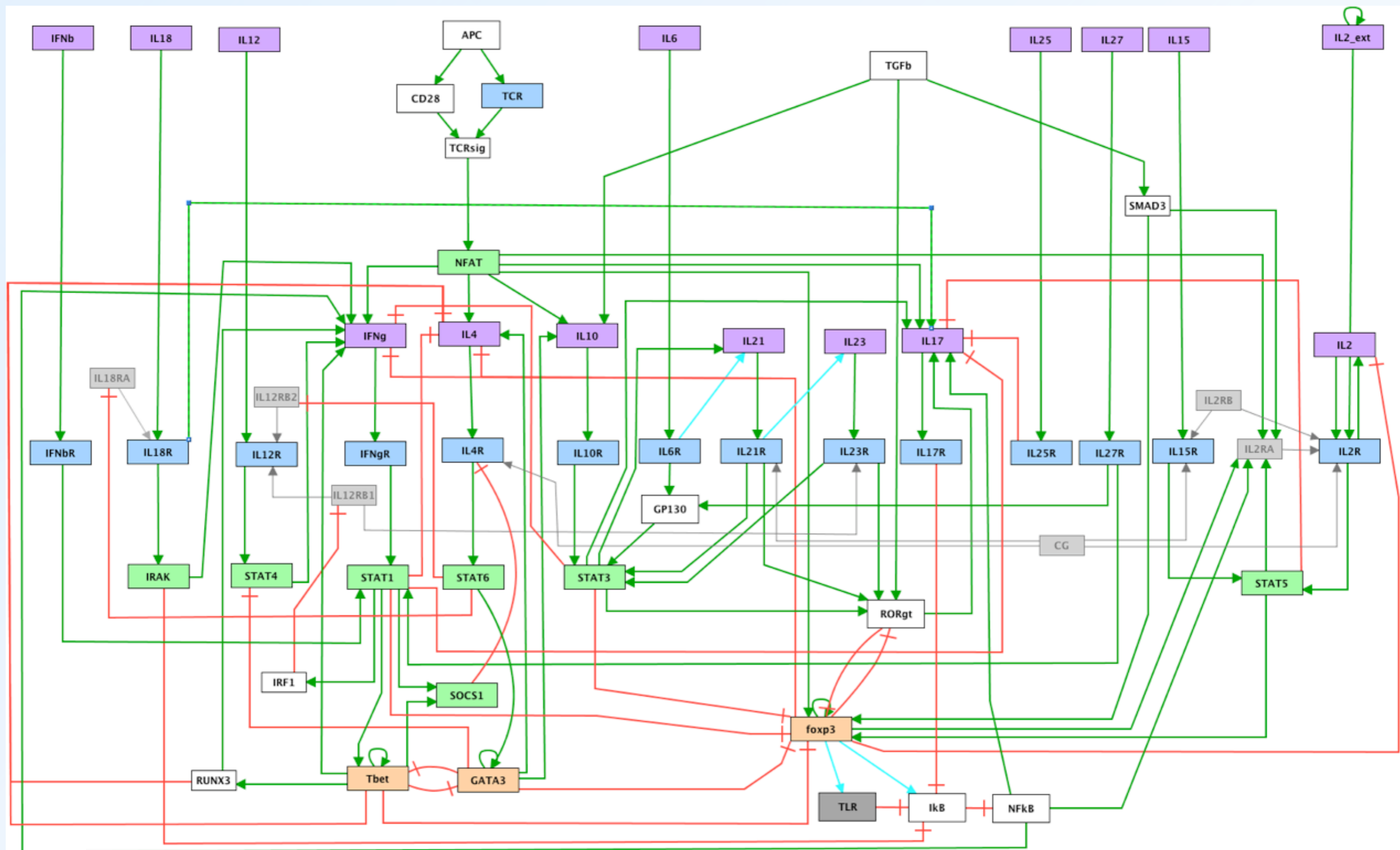

Multi-cellular networks: Drosophila wing disc

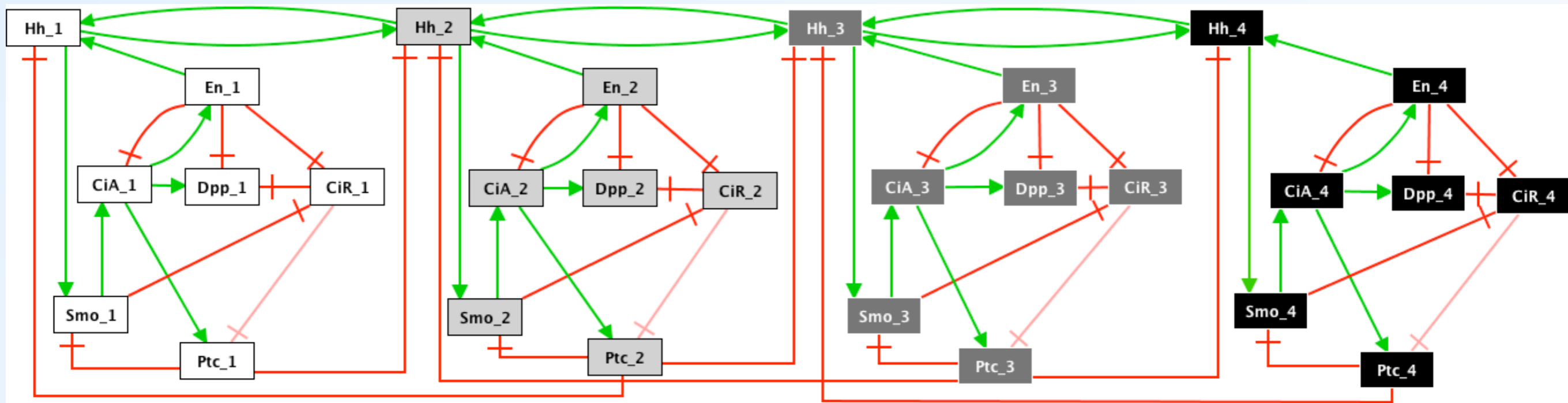

González AG, Chaouiya C, Thieffry D (2008).

Qualitative dynamical modelling of the formation of the anterior-posterior compartment boundary in the Drosophila wing imaginal disc.

Bioinformatics **24**: i234-40.